

# HITS LIKE AIR WITHOUT THE VIBRATION

Vibration absorbing housing moves independently of the motor and hammer mechanism effectively isolating more vibration away from the user

Mechanical counterbalance system greatly reduces vibration and directs more impact energy to the work surface

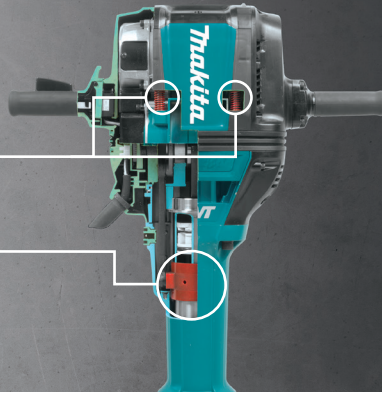

**HM1812X3**  
70 lb. Advanced AVT® Breaker Hammer  
accepts 1-1/8" hex bits

- Hits like air without the vibration
- Efficient 15 AMP motor with improved hammer mechanism delivers 53.9 ft.lbs./72.8 joules of impact energy
- Advanced AVT® is a mechanical counterbalance, vibration absorbing housing and rubberized fixed handles designed to more effectively reduce vibration



**AVT** 42LB.

**HM1317CB**  
42 lb. AVT® Demolition Hammer accepts 1-1/8" Hex bits

- Powerful 14 AMP motor delivers 25.7 ft.lbs. of impact energy to handle the most demanding applications
- Anti-Vibration Technology is an internal counterbalance system that greatly reduces vibration
- Variable speed control dial enables user to match the speed to the application for greater versatility



**35LB.**

**HM1307CB**  
35 lb. Demolition Hammer accepts 1-1/8" Hex bits

- Powerful 14 AMP motor delivers 25.7 lbs. of impact energy to handle the most demanding applications
- Constant Speed Control automatically applies additional power to the motor to maintain consistent speed under load for the most challenging jobs
- Soft Start suppresses start-up reaction for smoother start-ups and better accuracy

DUST EXTRACTION ATTACHMENT



**197172-1**  
Dust Extraction Attachment, SDS-MAX, Demolition

- Use with HM1307CB, HM1317CB, and HM1812X3

**AVT** 27LB.



**HM1214C**  
27 lb. AVT® Demolition Hammer accepts SDS-MAX bits

- Powerful 14 AMP motor delivers 19 ft.lbs. of impact energy to handle the most demanding applications
- Soft start suppresses start-up reaction for more precision and better accuracy

**20LB.**



**HM1203C**  
20 lb. Demolition Hammer accepts SDS-MAX bits

- Powerful 14 AMP motor delivers 18.8 ft.lbs. of impact energy
- Constant speed control automatically applies additional power to the motor to maintain speed under load

**AVT** 17LB.



**HM1111C**  
17 lb. AVT® Demolition Hammer accepts SDS-MAX bits

- Powerful 14 AMP motor delivers 12.7 ft.lbs. of impact energy to handle the most demanding applications
- Anti-Vibration Technology is an internal counterbalance system that greatly reduces vibration

**11LB.**



**HM0870C**  
11 lb. Demolition Hammer accepts SDS-MAX bits

- Powerful 10 AMP motor delivers 8.4 ft.lbs. of impact energy to handle the most demanding applications
- Variable speed control dial enables user to match the speed to the application for greater versatility

DUST EXTRACTION ATTACHMENT



**196571-4**  
Dust Extraction Attachment, 1-1/8", Demolition

- Use with HR1111C, HM0870C, HM1203C, and HM1214C

DEMOLITION HAMMER STEEL		1-1/8"	3/4" Hex	SDS-MAX	Spline or 3/4" Hex - 21/32" Round	SDS-PLUS
Description	Diameter	Part #	Diameter	Part #	Diameter	Part #
<b>Bull Point</b> Demolition applications and starts holes in concrete	20-1/2" / 16"	D-21353* / B-45559	12" / 18"	751421-A / 751422-A	12" / 18"	751423-A / 751424-A
<b>Flat Chisel</b> General purpose chipping, edging and channelling	(Self-Sharpening) 20-1/2"	D-21369*	1" x 12" / 1" x 18"	751224-A / 751225-A	1" x 12" / 1" x 18"	751228-A / 751231-A
<b>Scaling Chisel</b> Wide chisel with two cutting angles for chipping dried concrete	3" x 20-1/2"	D-21347*	3" x 12"	751226-A	1" x 12" / 2" x 12" / 3" x 12"	751235-A / 751229-A / 751230-A
<b>Floor Scraper</b> Cleanly Removes Tile, Linoleum and Flooring Adhesive	—	—	—	—	6" wide	T-02593
<b>One Piece Bushing Tool</b> Removes excess concrete and roughens surface	1-3/4" x 14-3/4"	751717-A	1-3/4" x 9-3/4"	751714-A	1-3/4" x 10"	751715-A
<b>Asphalt Cutter</b> Cuts asphalt or hard ground (not for use in concrete)	5" x 17-1/2"	751620-A	5" x 15"	751624-A	5" x 15"	751625-A
<b>Clay Spade</b> Digs clay, shale, hard packed gravel and dirt	5-1/2" x 20"	751622-A	4-1/2" x 17"	751623-A	4-1/2" x 17"	751626-A
<b>Ground Rod Driver</b> Drives ground rods into the ground	1" I.D. x 2-1/4" x 16"	751102-A	3/4" I.D. x 2-3/4" x 10"	751105-A	3/4" I.D. x 2-3/4" x 10"	751108-A

\*Also fits Air Tools