



**ProStock**

# **PVC/ABS DWV**

## **FITTINGS CATALOG**



# Methods of Designating Fitting Inlets:

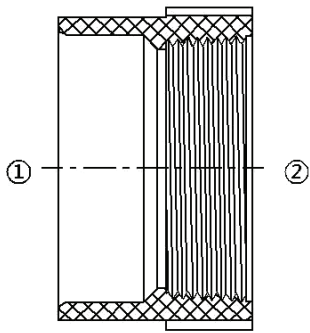

Female Adapter

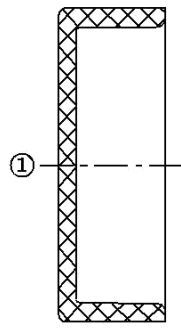

Cap

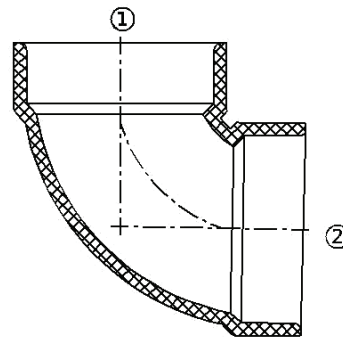

90° Elbow

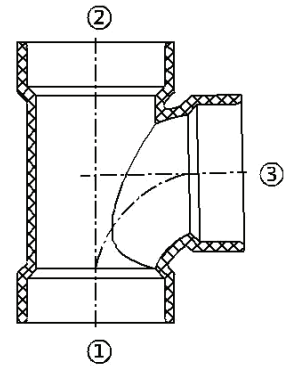

Sanitary Tee

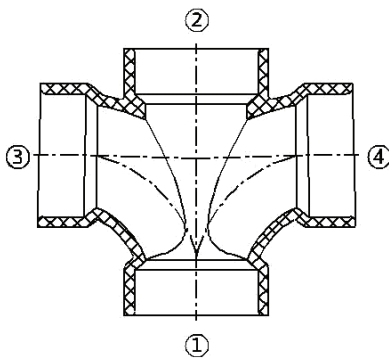

Double Sanitary Tee

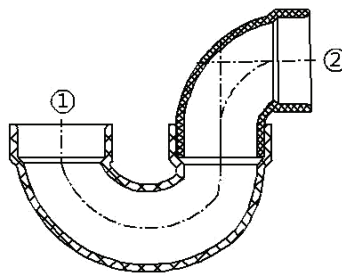

P-Trap

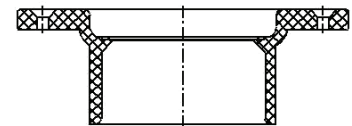

Closet Flange

## PVC DIMENSIONAL CATALOG

### PVC DWV FITTINGS

COUPLING		HUB X HUB					
SIZE	PART NUMBER	CTN QTY	Dimensions				
			A	B	C	D	E
1-1/2"	82933	130	1/8				
2"	82934	70	1/8				
3"	82935	60	3/16				
4"	82936	30	1/4				

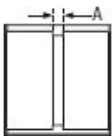

**ADAPTER • FEMALE H x FPT**



SIZE	PART NUMBER	CTN QTY	Dimensions				
			A	B	C	D	E
1-1/2"	82866	100	1-5/8	15/16	1/4		
2"	82867	80	1-7/8	1	1/4		
3"	82869	78	3-1/32	1-27/32	5/16		

**PIPE INCREASER • REDUCER H x H**



SIZE	PART NUMBER	CTN QTY	Dimensions				
			A	B	C	D	E
2" x 1-1/2"	82948	100	17/32				
3" x 1-1/2"	82949	60	17/16				
3" x 2"	82950	60	7/8				
4" x 2"	82951	60	1-3/8				
4" x 3"	82952	60	5/8				

**TRAP ADAPTER • MALE • W/PLASTIC NUT & 1-1/2" & 1-1/4" WASHERS SP x SJ**

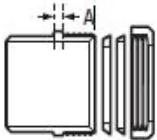

SIZE	PART NUMBER	CTN QTY	Dimensions				
			A	B	C	D	E
1-1/2"	83389	90	3/16				

**TRAP ADAPTER • FEMALE • W/PLASTIC NUT & WASHER H x SJ**

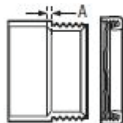

SIZE	PART NUMBER	CTN QTY	Dimensions				
			A	B	C	D	E
1-1/2"	83383	90	3/16				

**ADAPTER • CLEANOUT • W/CLEANOUT PLUG**

**SP x FPT**

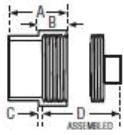

SIZE	PART NUMBER	CTN QTY	Dimensions				
			A	B	C	D	E
1-1/2"	83001	90	1-5/8	7/8	5/32	1-15/32	
2"	83002	180	1-17/32	29/32	5/32	1-1/2	

**PLUG • CLEANOUT**

**MPT**

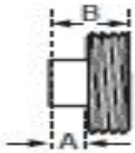

SIZE	PART NUMBER	CTN QTY	Dimensions				
			A	B	C	D	E
1-1/2"	82938	150	5/8	1-3/8			
2"	82939	150	5/8	1-3/8			
3"	82941	120	3/4	1-3/4			
4"	82942	100	7/8	1-7/8			

**BUSHING • FLUSH**

**SP x H**

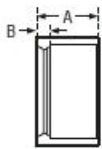

SIZE	PART NUMBER	CTN QTY	Dimensions				
			A	B	C	D	E
2" x 1-1/2"	82906	100	1-1/16	5/16			
3" x 2"	82908	100	1-1/2	3/4			
4" x 2"	82910	90	2	1/4			
4" x 3"	82909	90	1-3/4	1/4			

**ADAPTER • MALE**

**H x MPT**

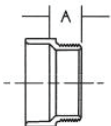

SIZE	PART NUMBER	CTN QTY	Dimensions				
			A	B	C	D	E
1-1/2"	82927	100	3/16				
2"	82928	100	3/16				
3"	82929	120	3/8				

### CAP • SOCKET H

	SIZE	PART	CTN	Dimensions				
		NUMBER	QTY	A	B	C	D	E
	1-1/2"	82977	100	1-1/16				
2"	82978	100	1-3/16					
3"	82979	100	2-1/4					
4"	82980	55	2-5/16					

### ELBOW • 1/4 BEND H x H

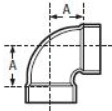
	SIZE	PART	CTN	Dimensions				
		NUMBER	QTY	A	B	C	D	E
	1-1/2"	82876	100	1-3/4				
2"	82877	100	2-5/16					
3"	82878	100	3-1/16					
4"	82879	100	3-7/8					

### ELBOW • STREET • 1/4 BEND SP x H

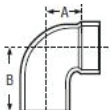
	SIZE	PART	CTN	Dimensions				
		NUMBER	QTY	A	B	C	D	E
	1-1/2"	82880	100	1-3/4	2-7/16			
2"	82881	100	2-5/16	3-1/16				
3"	82882	100	3-1/16	4-9/16				

### ELBOW • STREET • 1/4 BEND • W/LOW HEEL INLET ALL HUB

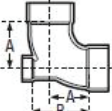
	SIZE	PART	CTN	Dimensions				
		NUMBER	QTY	A	B	C	D	E
	3" x 3" x 2"	83042	100	3-1/16	4-7/16			

**ELBOW • LONG SWEEP • 1/4 BEND      H x H**

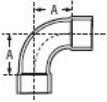
	SIZE	PART	CTN	Dimensions				
		NUMBER	QTY	A	B	C	D	E
	1-1/2"	82871	100	2-3/4				
	2"	82872	60	3-1/4				
	3"	82873	28	4-1/16				
	4"	82874	16	4-15/16				

**ELBOW • 1/8 BEND      H x H**

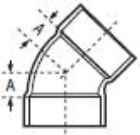
	SIZE	PART	CTN	Dimensions				
		NUMBER	QTY	A	B	C	D	E
	1-1/2"	82885	100	1-1/8				
	2"	82886	90	1-1/2				
	3"	82887	48	1-3/4				
	4"	82888	24	2-3/16				

**ELBOW • 1/8 BEND • STREET      SP x H**

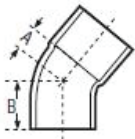
	SIZE	PART	CTN	Dimensions				
		NUMBER	QTY	A	B	C	D	E
	1-1/2"	82890	100	1-1/8	1-13/16			
	2"	82891	100	1-1/2	2-1/4			
	3"	82892	52	1-3/4	3-1/4			
	4"	82893	24	2-3/16	3-15/16			

**ELBOW • 1/16 BEND      H x H**

	SIZE	PART	CTN	Dimensions				
		NUMBER	QTY	A	B	C	D	E
	1-1/2"	82899C	70	1/2				
	2"	82900C	100	1-1/16				
	3"	82901C	36	1-3/16				
	4"	82983C	36	1-5/16				

**ELBOW • 1/16 BEND • STREET SP x H**

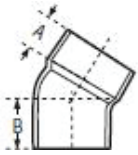

SIZE	PART	CTN	Dimensions				
	NUMBER	QTY	A	B	C	D	E
1-1/2"	82984	70	7/16	1-3/16			
2"	82985	100	5/8	1-1/2			

**ELBOW • CLOSET BEND • REDUCING • H x H**

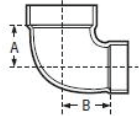

SIZE	PART	CTN	Dimensions				
	NUMBER	QTY	A	B	C	D	E
4" x 3"	83093	30	3	3-3/8			

**ELBOW • VENT ELL H x H**

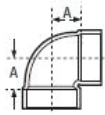

SIZE	PART	CTN	Dimensions				
	NUMBER	QTY	A	B	C	D	E
1-1/2"	83084	100	1-3/16				
2"	83085	100	1 1/2				

**TEE • SANITARY ALL HUB**

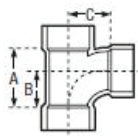

SIZE	PART	CTN	Dimensions				
	NUMBER	QTY	A	B	C	D	E
1-1/2"	82752	100	2-3/4	1-3/4	1-3/4		
2"	82753	54	3-11/16	2-5/16	2-5/16		
3"	82754	28	4-7/8	3-1/16	3-1/16		
4"	82755	10	6-1/8	3-7/8	3-7/8		

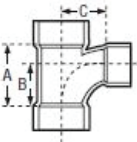

TEE • SANITARY ALL HUB								
	SIZE	PART	CTN	Dimensions				
		NUMBER	QTY	A	B	C	D	E
	2" x 1-1/2" x 1-1/2"	82761	65	3-1/8	1-15/16	2-3/16		
	2" x 1-1/2" x 2"	82760	60	3-11/16	2-5/16	2-5/16		
	2" x 2" x 1-1/2"	82758	64	3-1/8	1-15/16	2-3/16		
	3" x 3" x 1-1/2"	82764	40	2-11/16	1-3/4	2-9/16		
	3" x 3" x 2"	82763	40	3-5/16	3-5/16	2-7/8		

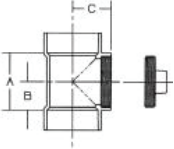
TEE • CLEANOUT • W/CLEANOUT PLUG H x H x FPT								
	SIZE	PART	CTN	Dimensions				
		NUMBER	QTY	A	B	C	D	E
	1-1/2"	82997		2 3/8	1 3/16	1 13/16		
	2"	82998		3	1 1/2	2 1/8		
	3"	82999		3 3/4	1 7/8	2 5/8		
	4"	83000		5	2 1/2	3 3/8		

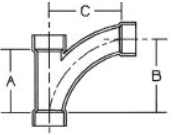
COMBINATION WYE & 1/8 BEND-ONE PIECE ALL HUB								
	SIZE	PART	CTN	Dimensions				
		NUMBER	QTY	A	B	C	D	E
	1-1/2"	82853		3-1/2	3 7/8	3 15/16		
	2"	82858		4 7/16	5 1/8	5 1/8		
	3"	82852		6 1/2	7 9/16	7 9/16		
	4"	82860		8 1/2	10	10		

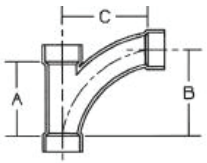
COMBINATION WYE & 1/8 BEND • REDUCING • ONE PIECE ALL HUB								
	SIZE	PART	CTN	Dimensions				
		NUMBER	QTY	A	B	C	D	E
	3" x 3" x 2"	82857		4-7/16	5-1/8	5-11/16		
	4" x 4" x 2"	82863		4-1/2	5-1/8	6-1/8		
	4" x 4" x 3"	82864		6-1/2	7-9/16	8-1/16		

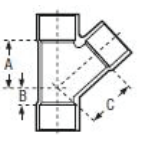

WYE ALL HUB								
	SIZE	PART	CTN	Dimensions				
		NUMBER	QTY	A	B	C	D	E
	1-1/2"	82822		2-7/8	1-1/8	2-7/8		
	2"	82823		3-5/8	1-3/8	3-5/8		
	3"	82824		5	1-5/8	5		
4"	82825		6-3/8	1-7/8	6-3/8			

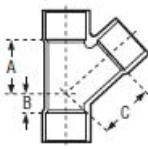
WYE • REDUCING ALL HUB								
	SIZE	PART	CTN	Dimensions				
		NUMBER	QTY	A	B	C	D	E
	2" x 1-1/2" x 1-1/2"	82831		2-13/16	3/4	2-15/16		
	2" x 2" x 1-1/2"	82826		3-5/16	1-1/16	3-7/16		
	3" x 3" x 1-1/2"	82827		3-3/4	1/2	4-5/16		
	3" x 3" x 2"	82828		4-1/8	7/8	4-5/8		
	4" x 4" x 2"	82829		4-11/16	3/8	5-9/16		
4" x 4" x 3"	82830		5-9/16	1-1/16	6			

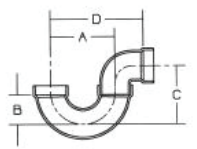
P-TRAP • W/SOLVENT WELD JOINT H x H								
	SIZE	PART	CTN	Dimensions				
		NUMBER	QTY	A	B	C	D	E
	1-1/2"	82214	55	3-1/2	1-17/32	3-5/8	4-23/32	
	2"	82222	25	5-1/4	2-3/8	5-1/8	6-7/8	
	3"	82230	8	6 5/16	3-11/16	7-9/16	12-7/16	

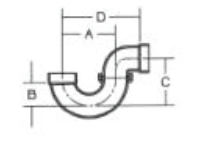
P-TRAP • W/UNION H x H								
	SIZE	PART	CTN	Dimensions				
		NUMBER	QTY	A	B	C	D	E
	1-1/2"	82215	55	3-1/2	1-17/32	3-5/8	4-23/32	
	2"	82216	25	5-1/4	2-3/8	5-1/8	6-7/8	

# Methods of Designating Fitting Inlets:

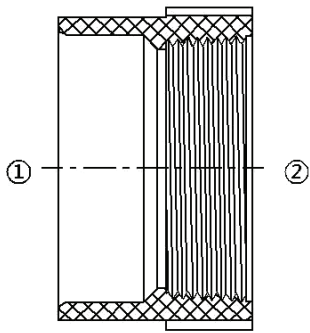

Female Adapter

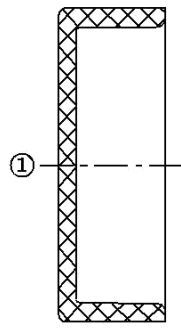

Cap

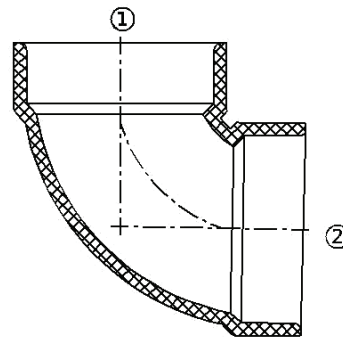

90° Elbow

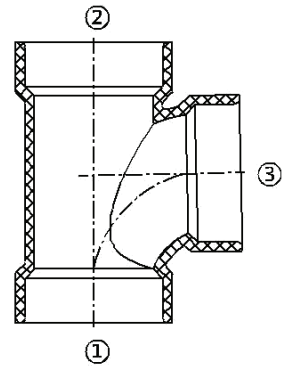

Sanitary Tee

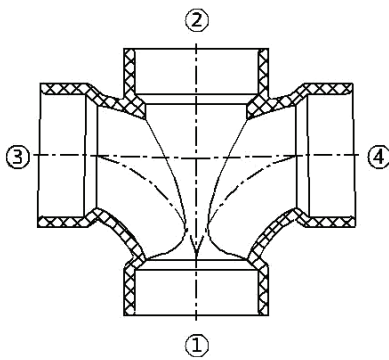

Double Sanitary Tee

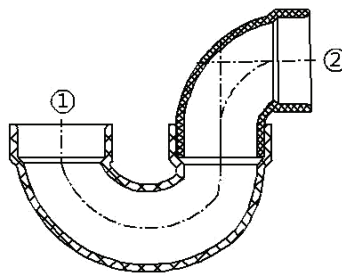

P-Trap

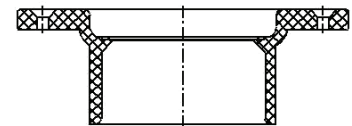

Closet Flange

## ABS DIMENSIONAL CATALOG

### ABS DWV FITTINGS

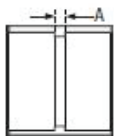

SIZE	PART NUMBER	CTN QTY	Dimensions				
			A	B	C	D	E
1-1/2"	2933	130	1/8				
2"	2934	70	1/8				
3"	2935	60	3/16				
4"	2936	30	1/4				

### ADAPTER • FEMALE H x FPT

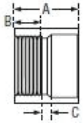

SIZE	PART NUMBER	CTN QTY	Dimensions				
			A	B	C	D	E
1-1/2"	2866	100	1-5/8	15/16	1/4		
2"	2867	80	1-7/8	1	1/4		
3"	2869	78	3-1/32	1-27/32	5/16		

### PIPE INCREASER • REDUCER H x H



SIZE	PART NUMBER	CTN QTY	Dimensions				
			A	B	C	D	E
2" x 1-1/2"	2948	100	17/32				
3" x 1-1/2"	2949	60	17/16				
3" x 2"	2950	60	7/8				
4" x 2"	2951	60	1-3/8				
4" x 3"	2952	60	5/8				

### TRAP ADAPTER • MALE • W/PLASTIC NUT & 1-1/2" & 1-1/4" WASHERS SP x SJ

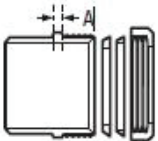

SIZE	PART NUMBER	CTN QTY	Dimensions				
			A	B	C	D	E
1-1/2"	3389	90	3/16				

### TRAP ADAPTER • FEMALE • W/PLASTIC NUT & WASHER H x SJ

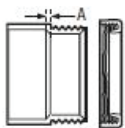

SIZE	PART NUMBER	CTN QTY	Dimensions				
			A	B	C	D	E
1-1/2"	3383	90	3/16				
1-1/2" x 1-1/4"	3384	100	3/16				

**ADAPTER • CLEANOUT • W/CLEANOUT PLUG**

**SP x FPT**

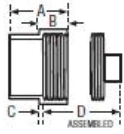

SIZE	PART NUMBER	CTN QTY	Dimensions				
			A	B	C	D	E
1-1/2"	3001	90	1-5/8	7/8	5/32	1-15/32	
2"	3002	180	1-17/32	29/32	5/32	1-1/2	

**PLUG • CLEANOUT**

**MPT**

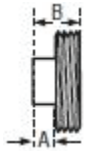

SIZE	PART NUMBER	CTN QTY	Dimensions				
			A	B	C	D	E
1-1/2"	2938	150	5/8	1-3/8			
2"	2939	150	5/8	1-3/8			
3"	2941	120	3/4	1-3/4			
4"	2942	100	7/8	1-7/8			

**BUSHING • FLUSH**

**SP x H**

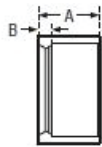

SIZE	PART NUMBER	CTN QTY	Dimensions				
			A	B	C	D	E
2" x 1-1/2"	2906	100	1-1/16	5/16			
3" x 2"	2908	100	1-1/2	3/4			
4" x 2"	2910	90	2	1/4			
4" x 3"	2909	90	1-3/4	1/4			

**ADAPTER • MALE**

**H x MPT**

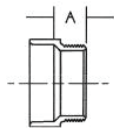

SIZE	PART NUMBER	CTN QTY	Dimensions				
			A	B	C	D	E
1-1/2"	2927	100	3/16				
2"	2928	100	3/16				
3"	2929	120	3/8				

**CAP • SOCKET    H**

	SIZE	PART NUMBER	CTN QTY	Dimensions				
				A	B	C	D	E
	1-1/2"	2977	100	1-1/16				
	2"	2978	100	1-3/16				
	3"	2979	100	2-1/4				
4"	2980	55	2-5/16					

**ELBOW • 1/4 BEND    H x H**

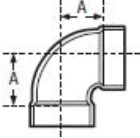
	SIZE	PART NUMBER	CTN QTY	Dimensions				
				A	B	C	D	E
	1-1/2"	2876C	100	1-5/16				
	2"	2877C	100	1-3/5				
	3"	2878C	100	2-7/20				
4"	2879C	100	3					

**ELBOW • STREET • 1/4 BEND    SP x H**

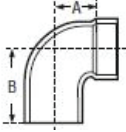
	SIZE	PART NUMBER	CTN QTY	Dimensions				
				A	B	C	D	E
	1-1/2"	2880C	100	1-5/16	2			
	2"	2881C	100	1-3/5	2-7/10			
	3"	2882C	100	2-7/20	3-5/6			
4"	2883C	100	3	4-3/4				

**ELBOW • STREET • 1/4 BEND • W/LOW HEEL INLET    ALL HUB**

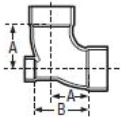
	SIZE	PART NUMBER	CTN QTY	Dimensions				
				A	B	C	D	E
	3" x 3" x 2"	3042	100	3-1/16	4-7/16			

**ELBOW • LONG SWEEP • 1/4 BEND      H x H**

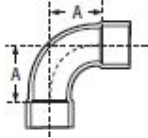
	SIZE	PART	CTN	Dimensions				
		NUMBER	QTY	A	B	C	D	E
	1-1/2"	2871	100	2-3/4				
	2"	2872	60	3-1/4				
	3"	2873	28	4-1/16				
	4"	2874	16	4-15/16				

**ELBOW • 1/8 BEND      H x H**

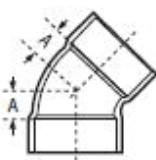
	SIZE	PART	CTN	Dimensions				
		NUMBER	QTY	A	B	C	D	E
	1-1/2"	2885C	100	9/16				
	2"	2886C	90	5/8				
	3"	2887C	48	7/8				
	4"	2888C	24	1				

**ELBOW • 1/8 BEND • STREET      SP x H**

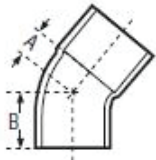
	SIZE	PART	CTN	Dimensions				
		NUMBER	QTY	A	B	C	D	E
	1-1/2"	2890C	100	9/16	1 1/5			
	2"	2891C	100	5/8	1-2/5			
	3"	2892C	52	7/8	2-9/25			
	4"	2893C	24	1	2-3/4			

**ELBOW • 1/16 BEND      H x H**

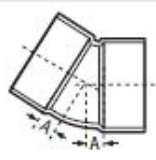
	SIZE	PART	CTN	Dimensions				
		NUMBER	QTY	A	B	C	D	E
	1-1/2"	2899C	70	1/2				
	2"	2900C	100	1-1/16				
	3"	2901C	36	1-3/16				
	4"	2983C	36	1-5/16				

**ELBOW • 1/16 BEND • STREET SP x H**

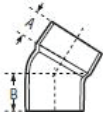

SIZE	PART	CTN	Dimensions				
	NUMBER	QTY	A	B	C	D	E
1-1/2"	2984	70	7/16	1-3/16			
2"	2985	100	5/8	1-1/2			

**ELBOW • CLOSET BEND • REDUCING • H x H**

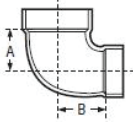

SIZE	PART	CTN	Dimensions				
	NUMBER	QTY	A	B	C	D	E
4" x 3"	3093	30	3	3-3/8			

**ELBOW • VENT ELL H x H**

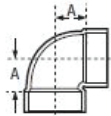

SIZE	PART	CTN	Dimensions				
	NUMBER	QTY	A	B	C	D	E
1-1/2"	3084	100	1-3/16				
2"	3085	100	1 1/2				

**TEE • SANITARY ALL HUB**

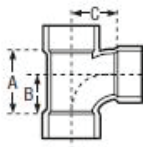

SIZE	PART	CTN	Dimensions				
	NUMBER	QTY	A	B	C	D	E
1-1/2"	2752	100	2-3/4	1-3/4	1-3/4		
2"	2753	54	3-11/16	2-5/16	2-5/16		
3"	2754	28	4-7/8	3-1/16	3-1/16		
4"	2755	10	6-1/8	3-7/8	3-7/8		

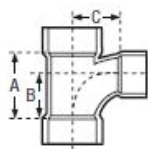

TEE • SANITARY ALL HUB								
	SIZE	PART	CTN	Dimensions				
		NUMBER	QTY	A	B	C	D	E
	2" x 1-1/2" x 1-1/2"	2761	65	3-1/8	1-15/16	2-3/16		
	2" x 1-1/2" x 2"	2760	60	3-11/16	2-5/16	2-5/16		
	2" x 2" x 1-1/2"	2758	64	3-1/8	1-15/16	2-3/16		
	3" x 3" x 1-1/2"	2764	40	2-11/16	1-3/4	2-9/16		
3" x 3" x 2"	2763	40	3-5/16	3-5/16	2-7/8			

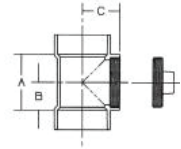
TEE • CLEANOUT • W/CLEANOUT PLUG H x H x FPT								
	SIZE	PART	CTN	Dimensions				
		NUMBER	QTY	A	B	C	D	E
	1-1/2"	2997		2 3/8	1 3/16	1 13/16		
	2"	2998		3	1 1/2	2 1/8		
	3"	2999		3 3/4	1 7/8	2 5/8		
	4"	3000		5	2 1/2	3 3/8		

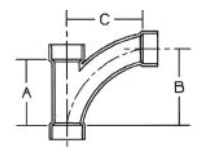
COMBINATION WYE & 1/8 BEND-ONE PIECE ALL HUB								
	SIZE	PART	CTN	Dimensions				
		NUMBER	QTY	A	B	C	D	E
	1-1/2"	2853		3-1/2	3 7/8	3 15/16		
	2"	2858		4 7/16	5 1/8	5 1/8		
	3"	2852		6 1/2	7 9/16	7 9/16		
	4"	2860		8 1/2	10	10		

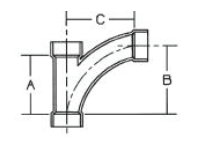
COMBINATION WYE & 1/8 BEND • REDUCING • ONE PIECE ALL HUB								
	SIZE	PART	CTN	Dimensions				
		NUMBER	QTY	A	B	C	D	E
	3" x 3" x 2"	2857		4-7/16	5-1/8	5-11/16		
	4" x 4" x 2"	2863		4-1/2	5-1/8	6-1/8		
	4" x 4" x 3"	2864		6-1/2	7-9/16	8-1/16		

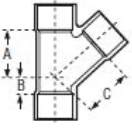
WYE ALL HUB								
	SIZE	PART	CTN	Dimensions				
		NUMBER	QTY	A	B	C	D	E
	1-1/2"	2822		2-7/8	1-1/8	2-7/8		
	2"	2823		3-5/8	1-3/8	3-5/8		
	3"	2824		5	1-5/8	5		
4"	2825		6-3/8	1-7/8	6-3/8			

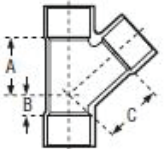
WYE • REDUCING ALL HUB								
	SIZE	PART	CTN	Dimensions				
		NUMBER	QTY	A	B	C	D	E
	2" x 1-1/2" x 1-1/2"	2831		2-13/16	3/4	2-15/16		
	2" x 2" x 1-1/2"	2826		3-5/16	1-1/16	3-7/16		
	3" x 3" x 1-1/2"	2827		3-3/4	1/2	4-5/16		
	3" x 3" x 2"	2828		4-1/8	7/8	4-5/8		
	4" x 4" x 2"	2829		4-11/16	3/8	5-9/16		
4" x 4" x 3"	2830		5-9/16	1-1/16	6			

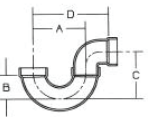
P-TRAP • W/SOLVENT WELD JOINT H x H								
	SIZE	PART	CTN	Dimensions				
		NUMBER	QTY	A	B	C	D	E
	1-1/2"	2214	55	3-1/2	1-17/32	3-5/8	4-23/32	
	2"	2222	25	5-1/4	2-3/8	5-1/8	6-7/8	
3"	2230	8	6 5/16	3-11/16	7-9/16	12-7/16		

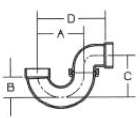
P-TRAP • W/UNION H x H								
	SIZE	PART	CTN	Dimensions				
		NUMBER	QTY	A	B	C	D	E
	1-1/2"	2215	55	3-1/2	1-17/32	3-5/8	4-23/32	
2"	2216	25	5-1/4	2-3/8	5-1/8	6-7/8		

# PVC AND ABS DWV FITTINGS

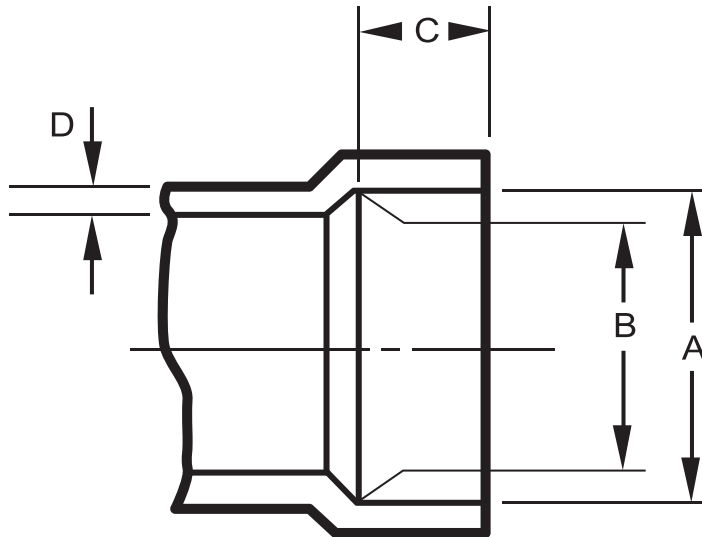

## PVC

SIZE	A	B	C	D
1.25	1.675	1.650	.687	.156
1.5	1.915	1.895	.687	.156
2	2.390	2.370	.750	.156
3	3.520	3.495	1.500	.218
4	4.520	4.495	1.750	.250
6	6.647	6.614	3.000	.281
8	8.655	8.610	4.000	.322
10	10.776	10.737	5.000	.365
12	12.778	12.736	6.000	.406
14	14.035	13.085	7.000	.437
16	16.045	15.980	8.000	.500

## ABS

SIZE	A	B	C	D
1.5	1.910	1.895	.687	.156
2	2.385	2.370	.750	.156
3	3.515	3.495	1.500	.218
4	4.515	4.495	1.750	.250
6	6.647	6.614	3.000	.281

## PVC STANDARDS

### **ASTM D1784 (Materials)**

This specification covers rigid poly(vinyl chloride) (PVC) compounds for use in extruded or molded form like pipe and fitting applications. Classification requirements for identifying rigid PVC shall be according to base resin, impact resistance under notch, tensile strength, modulus of elasticity in tension, deflection temperature under load, and flammability. PVC shall be in the form of cubes, granules, free-flowing powder blends, or compacted powder blends, and shall be of uniform size and free of foreign matter. The material shall conform to the test requirements such as tensile strength and modulus of elasticity, conditioning, impact resistance, deflection temperature, and flammability.

### **ASTM D2665 (Dimensions)**

This specification covers requirements and test methods for materials, dimensions and tolerances, pipe stiffness, crush resistance, impact resistance, hydrostatic burst resistance, and solvent cement for poly(vinyl chloride) plastic drain, waste, and vent pipe and fittings. The pipe and fittings covered are suitable for the drainage and venting of sewage and certain other liquid wastes. A form of marking is also included. The pipe and fittings shall be made of virgin PVC compounds of defined specification. The pipe shall conform to the required stiffness, deflection load and flattening. The fittings shall be subject to hydrostatic burst pressure. The pipe and fittings shall be subject to impact resistance test.

## ABS STANDARDS

### **ASTM D3965 (Materials)**

This specification covers materials from virgin ABS polymers and blends of ABS polymers suitable for use in the extrusion of pipe and molding of fittings.

### **ASTM D2661 (Dimensions)**

This specification cover fittings and single and coextruded acrylonitrile-butadiene-styrene (ABS) plastic drain, waste, and vent pipe (DMV) made to Schedule 40 iron pipe sizes (IPS). Plastic which does not meet material requirements specified in Section 5 is excluded from single layer and all coextruded layers.

### **CSA B181.1**

This standard specifies requirements for acrylonitrile-butadiene-styrene (ABS) drain, waste and vent (DWV) pipe, pipe fittings and accessories such as factory-assembled expansion joints, closet flanges, and backwater valves.



# ProStock

## WARRANTY

Products are warranted to be free from defects in material and workmanship for a period of three (3) year from date of installation. Products will be warranted to extent that Seller will replace, without charge, products proven to have manufacturing defects within that time frame and Seller has been given an opportunity to inspect alleged defective product.

### **Warranty is void where products:**

- are used for anything other than their intended purpose as defined by local plumbing and building code and industry standard.
- are not installed in good and workmanlike manner consistent with industry standard or products fail due to deficiencies in design or installation of piping system.
- have been modified or misused.
- fail due to freezing water or have come into contact with chemical agents not compatible.
- are caused to fail by forces outside of control of the Seller, including but not limited to: earthquake, flooding, lightning, or any other natural disaster or case of force majeure.

*If products found to be defective within warranty period, Seller will replace defective products or refund cost of said products to Buyer. Seller will not be responsible or liable for any expense arising from incidental or consequential damage to property, building, or otherwise.*

