

BACKED BY

UEi
SERVICE+

10
YEAR
WARRANTY

8
HR
SERVICE

ups
FREE
SHIPPING

C165+ OVERVIEW

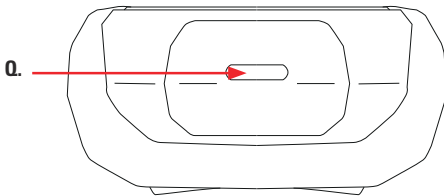
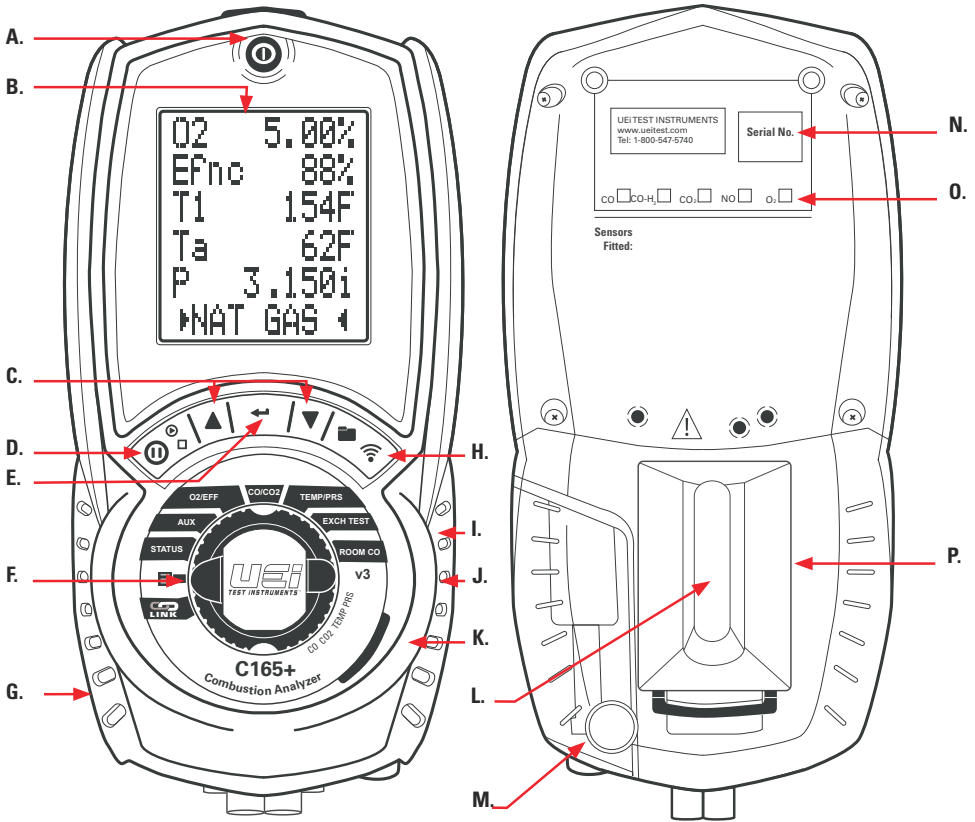

[Top View]

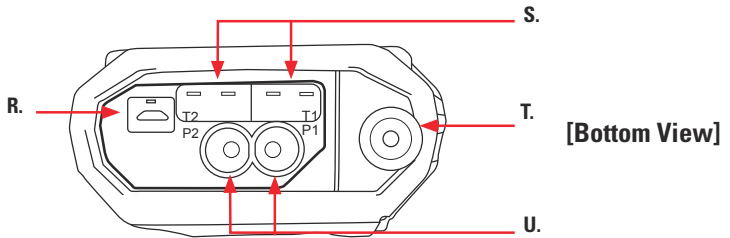

[Bottom View]

-
- A. On/ Off (Power) Button**
 - B. 6 Line Backlit Display**
 - Press any button to turn Back light on
 - C. UP/DOWN Button**
 - Short press to navigate “UP” or “DOWN”
 - D. Pump Toggle button:** Long press to pump on/off, short press holds the readings and the screen flashes
 - E. ENTER Button**
 - Short press select current option displayed
 - F. Rotary Dial**
 - G. Protective Rubber Boot With Magnets**
 - H. Printing and log button:** Long press to saving logs and Short press to print on/off
 - I. Water Trap** (under Protective Boot)
 - J. Particle Filter** (inside water trap)
 - K. LED Water Trap Indication:** LED is active while the pump is on to bring user awareness to any condensate building up in the water trap
 - L. Grip Indentation:** Indentation for fingers to grip analyzer
 - M. Water Trap Drain Plug:** (Red plug; take caution NOT to damage plug when removing protective boot)
 - N. Serial Number QR Code**
 - O. Sensors Fitted:** (label under Protective Boot) Indication of sensors installed when shipped (CO, CO-H₂, CO₂, NO, O₂)
 - P. Battery Compartment** (under Protective Boot)
 - Q. Infrared Printer Port**
 - R. Battery Charge USB Adapter Connection**
 - S. Temperature Connections**
 - Flue Probe Temperature: T1
 - Inlet Temperature: T2
 - T. Flue Gas Inlet Connection**
 - U. Pressure Connections**
 - Pressure: P1
 - Differential Pressure: P2

MENU SCREEN - C165+ START UP

Press **ⓘ** "Power" Button for 2 seconds. The analyzer will perform a 60 second purge. This should be done in fresh air.

Rotate Selector Dial to **MENU** to set up or customize your settings.

Selected parameter are highlighted with Display Line Lights on either side.

Use **▲** and **▼** **ARROW BUTTONS** to scroll menu options.

Press **←** **Button** to edit a parameter.

Press **▲** and **▼** **ARROW BUTTONS** to change contents of field.

Press **←** **Button** to enter content and move to next field.

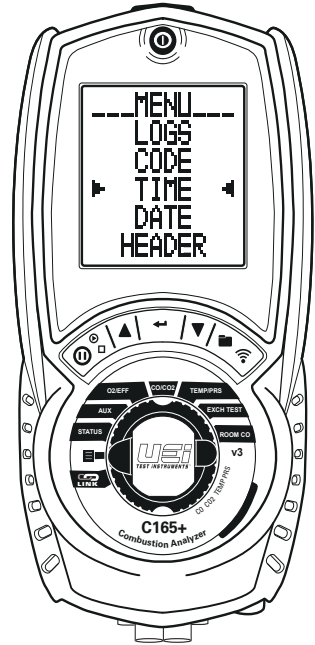

STATUS SCREEN

Rotate Selector Dial to **STATUS** to view parameters

Ta
ATM
CAL
SERIAL NUMBER
DATE
TIME
BATTERY LEVEL

Change Fuel Type

With the first line selected press **▲** and **▼** **ARROW BUTTONS** to change currently selected Fuel.

NAT GAS
H OIL
PELLETS
L OIL
LPG
BUTANE
PROPANE

Press **←** **Button** to select.

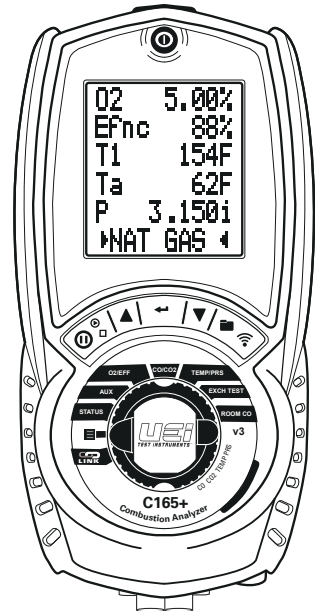

BEFORE TESTING

CHECKLIST

- Clean particle filter
- Water trap and probe line are free of condensate
- All hose and thermocouple connections are properly secured
- Water trap is fitted correctly
- Power on and zero
- Flue gas probe is sampling ambient **FRESH** air

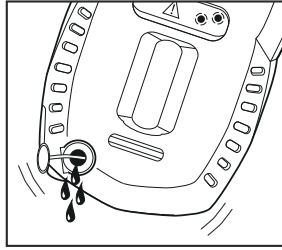

Remove the rubber boot and red drain plug. Allow the water to drain out. Re-insert the rubber plug and replace boot cover.

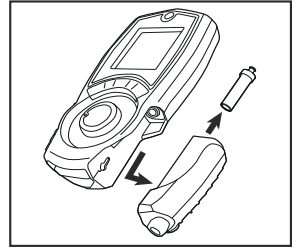

Remove protective rubber boot. Remove water trap from analyzer. Remove particle filter from water trap and replace with new one. Reattach trap and boot.

AUXILIARY SCREEN

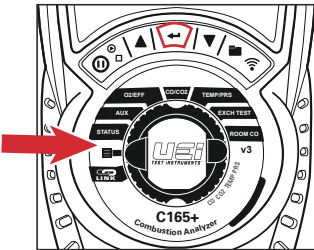



The **AUX** screen allows you to assign any of the following parameters on any display line. CO₂, CO, NO (if fitted), NO_x (if fitted), O₂, TF, T_i, T_a, Delta (Δ), Loss, EF_g, Xair, Ra (CO/CO₂ Ratio), PI, Fuel Type, PRS or Blank.



To customize the settings displayed on screen.

Rotate dial to .

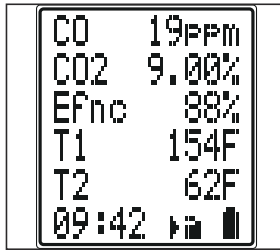

Scroll  or  to **SCREEN**. Press .



Scroll  or  to **AUX**. Press .



Scroll  or  to select the line to change. Press .

Highlighted line shows current selection.

Scroll  or  to change parameters. Press .

Scroll  or  to select another line to customize and repeat.

When finished, scroll  or  to **BACK**.

Press .

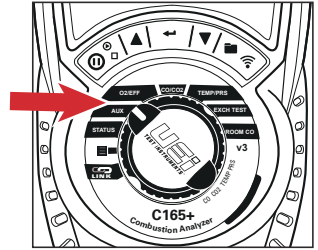

When performing a combustion Test.

Rotate function rotary dial to **AUX** to Test while viewing custom parameters that you selected.

BASIC CO/COMBUSTION ANALYSIS

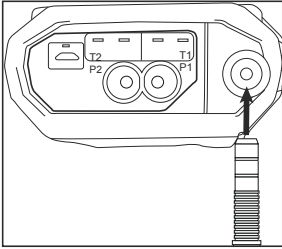

Insert Flue probe into stack.
Adjust cone so end of the probe is approximately at the center of the stack.

NOTE: You will have to drill a hole at least 3/8". Use appropriate sealing method after testing.

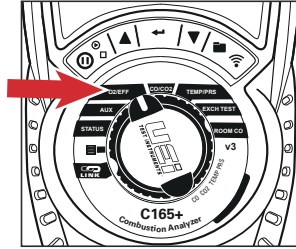

Rotate selector dial to **O2/Eff** to view:

O2
Efgc
T1
Ta
(Status Bar - NAT GAS)

Fuel type can be changed via  or **STATUS** setting

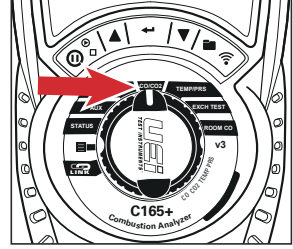

Rotate selector dial to **CO/CO2** to view:

CO
COa
CO2
LOSS
XAIR O2+
P
(Status Bar - NAT GAS)

Fuel type can be changed via  or **STATUS** setting.

Make any adjustments as needed for proper combustion and wait for analyzer to display change in readings. (Repeat as necessary).

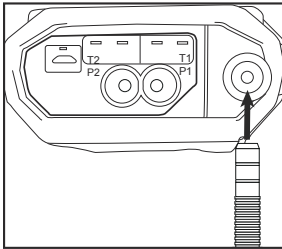

Once complete, remove probe from stack, allow analyzer to purge in fresh air until CO sensor readings return to ZERO (0) and O2 readings reading return to 20.9%.

Continue to the next test or power analyzer off by pressing  , if finished.

NOTE: Print and store functions may be used at any time during testing.

PRESSURE TEST

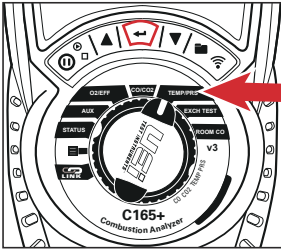

Rotate the selector dial to **PRS/TEMP**.

Press  to Zero Pressure sensor. No connections when zeroing pressure.

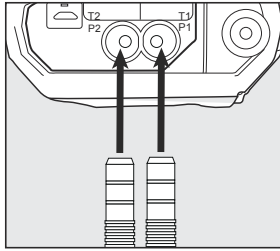

Connect true draft hose to P1. Connect second probe to P2 for differential pressure.

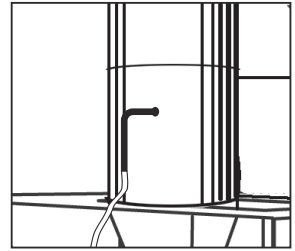

Place combustion probe or true draft probe tip in the flue to measure draft.

Connect static pressure hose to measure differential pressure.

TEMPERATURE TEST

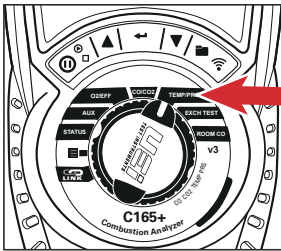

Rotate the selector dial to **PRS/TEMP**

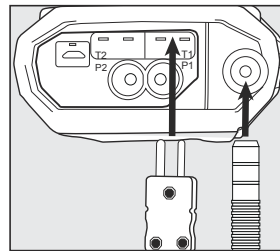

Connect probe to T1.

Compatible with any K-Type thermocouple probe or clamp.

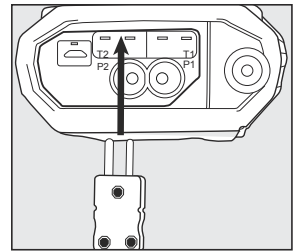

Connect second probe to T2.

Compatible with any K-Type thermocouple probe or clamp.

HEAT EXCHANGER TEST

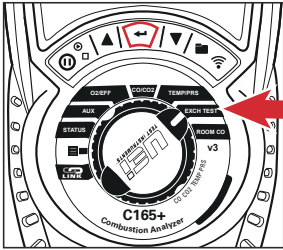

Rotate dial to **EXCH TEST**.
Press **←** to start.

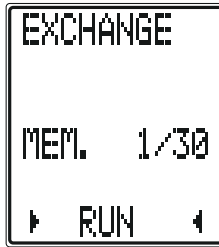

Scroll **▲** or **▼** to select **FUELTYPE**.
Press **←**

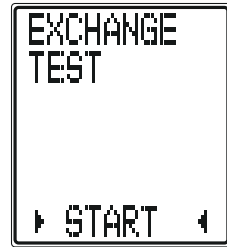

Call for heat on the system.
Observe and wait for O₂ readings to stabilize.

After the blower turns on,
press the **←** to start the Post-Blower test

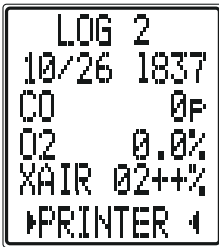

The analyzer will wait 60 seconds and then record the Post-Blower values for CO, O₂ and Excess Air.

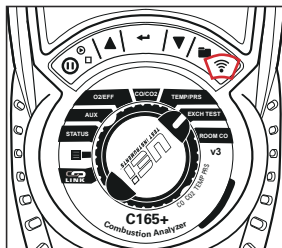
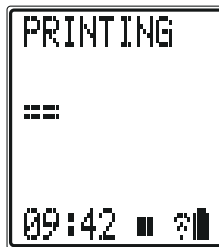

Test results and **LOG** number will display when done.

Press **📶** to print the results.
This **LOG** will be stored in **REPORTS/EXCHANGE** in the **MENU** screen.

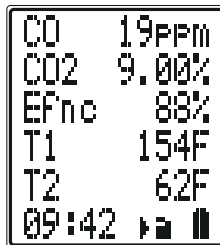

ROOM CO TEST

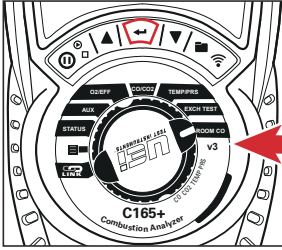

No probes or hose connections required for this test.

Rotate dial to **ROOM CO**.
Press to select **GENERAL** test type.

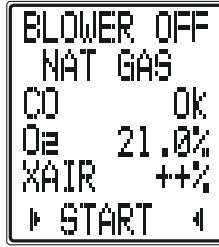

CO reading will be logged every minute for 30 minutes.

Readings will be stored once the 30 minute test is completed.

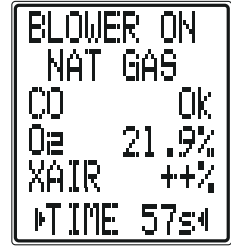

Test results and **LOG** number will display when done.

Press to print the results.

This **LOG** will be stored in **REPORTS/ROOM CO** in the **MENU** screen.

PRINTING AND LOGGING

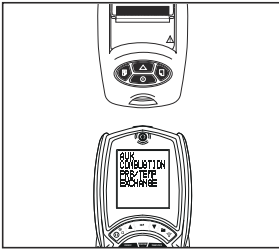

Align Printer in line above analyzer.

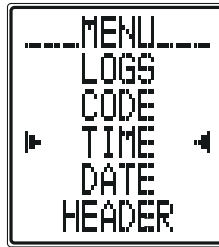

Rotate rotary dial to **Menu**.
Press or Buttons to select **Report**.

Press Button to select **Report**.



Press or Buttons to view types of **Reports**.

Press Button to select Report type.

Press Button to **View**.

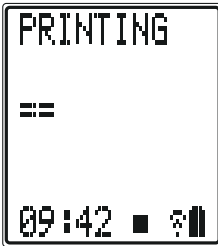

Press or Buttons to select Log number of that type of Report.

Scroll or to **PRINT**.

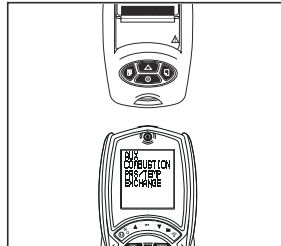

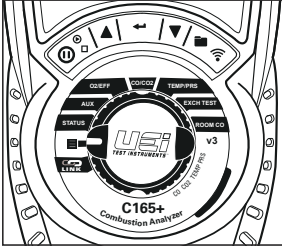

Press Button to print Report Log Number.

SETUP USER FUEL

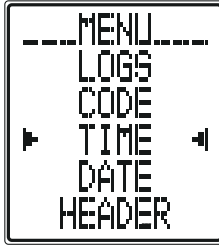

Rotate dial to **Menu**



UNITS shows press  to proceed.

POST TESTING

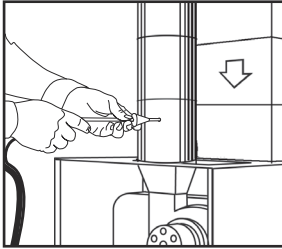

Remove the probe from the flue and allow analyzer to purge with fresh air until readings return to zero. O₂ to 20.9%

CAUTION: probe tip will be HOT.

POWERING OFF

When you power off the C165+, there is a 10 second purge.



CAUTION

Make sure you do not exceed the analyzer's operating specifications.

- Do not exceed the flue probes maximum temperature (1112°F)
- Do not exceed the analyzer's internal temperature range 112°F (50°C)
- Do not put the analyzer on a hot surface
- Do not exceed the water trap's level
- Do not let the particle filter become dirty and blocked

BATTERIES



The analyzer is fitted with 3 (AA) size rechargeable batteries. Observe correct polarity when replacing.

Always check operation immediately after battery replacement.

Do not leave batteries in unit for extended periods of non-use.



WARNING

Do not recharge with Alkaline batteries fitted. Alkaline batteries are not rechargeable. Attempting to recharge alkaline batteries may result in product damage and create a fire risk.

Time and Date will need to be reset after changing batteries.

Always dispose batteries using approved disposal methods that protect the environment.



**Download the full
Owners Manual at
UEiTEST.COM or
SCAN THIS CODE**

WARRANTY

The C165+ combustion analyzer is warranted for one year including sensors. If within the warranty period your instrument should become inoperative from such defects, the unit will be repaired or replaced at UEi's option. This warranty covers normal use and does not cover damage which occurs in shipment or failure which results from alteration, tampering, accident, misuse, abuse, neglect or improper maintenance (calibration). Batteries and consequential damage resulting from failed batteries are not covered by warranty. Any implied warranties, including but not limited to implied warranties of merchantability and fitness for a particular purpose, are limited to the express warranty. UEi shall not be liable for loss of use of the instrument or other incidental or consequential damages, expenses, or economic loss, or for any claim or claims for such damage, expenses or economic loss. A purchase receipt or other proof of original purchase date will be required before warranty repairs will be rendered. Instruments out of warranty will be repaired (when repairable) for a service charge. Warranty only covers hardware and does not extend to software applications or accessories. Contact UEi for specific warranty and service information.

This warranty gives you specific legal rights. You may also have other rights which vary from state to state.

ANNUAL RECERTIFICATION SERVICES



Complete Care for Your Combustion Analyzer

When you:

***Request Recertification or Service Online
Within 1 Year of Purchase or Last Service***

BACKED BY



UEi will:

10 Year Warranty: All UEi combustion analyzers have a standard 1-year warranty. Each recertification extends the warranty for 1 more year for up to **10 years** from the date of purchase.

10
YEAR
WARRANTY



Contractors who book recertification of a C160 series analyzer at www.ueitest.com/service within 12 months from either the date of purchase or the date of the last recertification will receive reduced service pricing that lowers the cost of ownership and 2 additional benefits:

Same Day Service: All qualifying analyzers received for recertification through UEi Service+ are returned on the same business day.*



Free Shipping: UEi Service+ offers free shipping both to and from our service center. When customers book their recertification, they receive a prepaid UPS Ground shipping label.

*Analyzers that include the additional NO (Nitric Oxide) sensor requires 48-hour turnaround.

Register Online

Registering you analyzer online is quick and easy. Just log in or setup an account, it only takes a couple of minutes. Once logged in you can register you analyzer by providing some product information and uploading a proof-of-purchase. When it's time to request recertification, just log into your account, select the analyzer, select the service and place your order.