



SERVICE PARTS LIST

BULLETIN NO.
54-24-2260

SPECIFY CATALOG NO. AND SERIAL NO. WHEN ORDERING PARTS		REVISED BULLETIN	DATE
M12™ FUEL™ 1/2" (13mm) HAMMER-DRILL			Feb. 2022
CATALOG NO.	3404-20	WIRING INSTRUCTION	
STARTING SERIAL NO.	M80A	See Page 2	

EXAMPLE:

00	0
----	---

 Component Parts (Small #)
 Are Included When Ordering
 The Assembly (Large #).

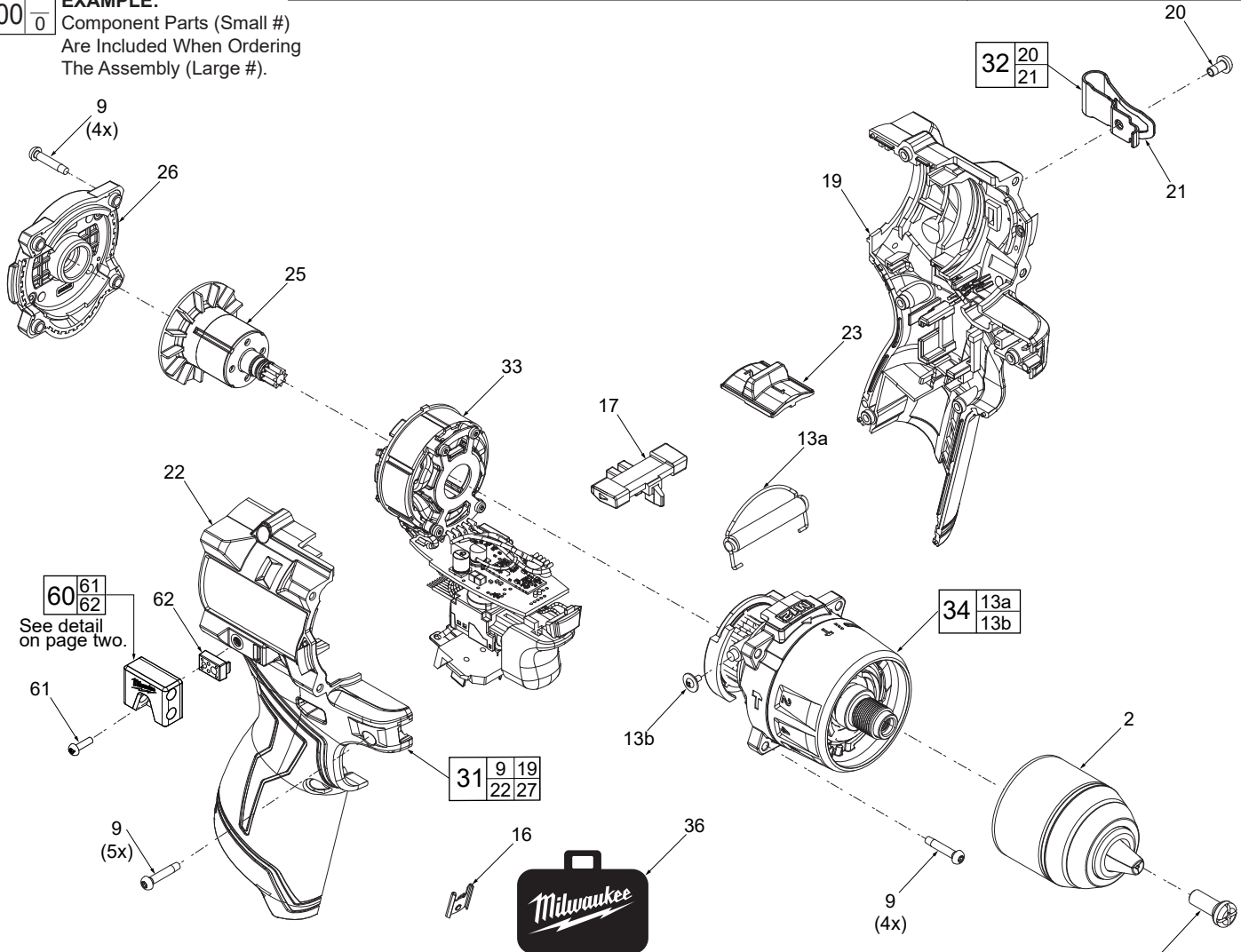

Apply Blue Loctite® thread locking sealant or the equivalent to the threads of the chuck screw (1) before securing chuck to the gearcase spindle.

FIG.	PART NO.	DESCRIPTION OF PART	NO. REQ.
1	05-88-0202	Chuck Screw	(1)
2	42-66-0400	1/2" (13mm) Keyless Chuck	(1)
9	06-82-6351	M3 x 16mm Pan Hd. ST T-10 Screw	(13)
13a	44-10-0195	Speed Selector Lever	(1)
13b	05-81-0542	M2.3 x 4.5mm Phillips Washer Screw	(2)
16	42-70-0058	Housing Clip	(1)
17	45-24-0560	Forward/Reverse Shuttle	(1)
19	-----	Housing Support - Left Housing Halve	(1)
20	05-88-1015	M2.5 x 6mm Pan Hd. Phillips Mach. Scr.	(1)
21	42-70-0117	Belt Clip	(1)
22	-----	Housing Cover - Right Housing Halve	(1)
23	45-24-0240	Speed Selector Slide Assembly	(1)
26	31-12-0052	End Cap Assembly	(1)
25	14-50-3000	Rotor	(1)
27	12-20-3404	Service Nameplate (not shown)	(1)
31	14-38-3402	Housing Kit	(1)
32	42-70-0497	Belt Clip Kit	(1)
33	14-20-3400	Electronics Assembly	(1)
34	14-29-0404	Gear Case Assembly	(1)
35	10-20-3554	LED Label (not shown)	(1)
36	42-55-0300	Zippered Tool Case	(1)
60	49-16-3697	Bit Holder Kit (Accessory)	(1)
61	06-82-3008	6-32 x 12.7mm Pan Hd. Philips Screw (for M12™)(Accessory)	(1)
62	-----	Adapter (for M12™) (Accessory)	(1)

SCREW TORQUE SPECIFICATION CHART			
FIG.	PART NO.	DESCRIPTION	SEATING TORQUE (IN-LBS)
1	05-88-0202	Chuck Screw	314.6±10.8
9	06-82-6351	Gearcase/Housing/Endcap Assembly Screw	6.9±0.9
13b	05-81-0542	Speed Selector Lever Screw	2.6±0.9
20	05-88-1015	Belt Clip Screw	12.2±1.7
61	06-82-3008	Bit Holder Screw	13.9±1.7

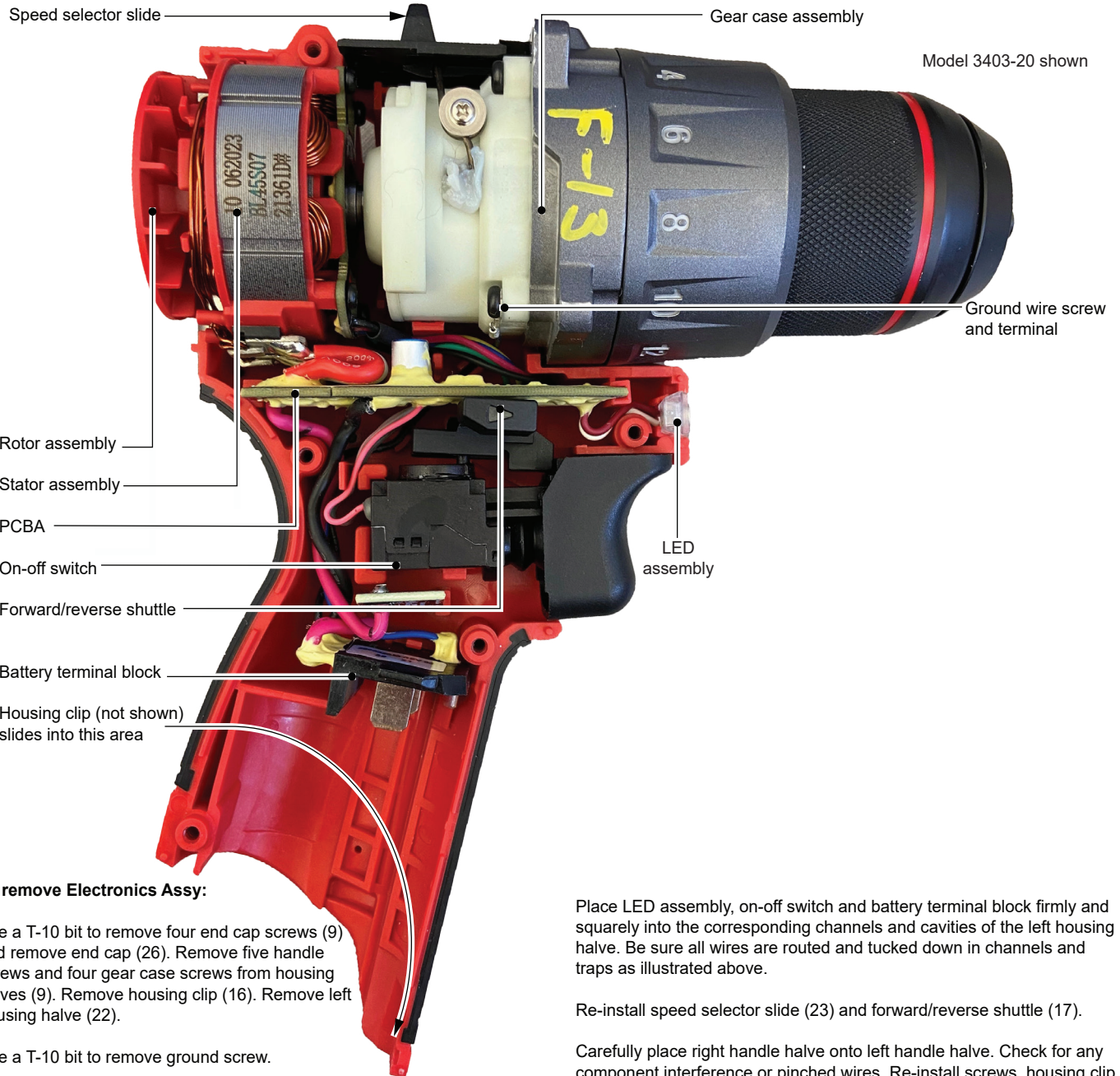

To remove Electronics Assy:

Use a T-10 bit to remove four end cap screws (9) and remove end cap (26). Remove five handle screws and four gear case screws from housing halves (9). Remove housing clip (16). Remove left housing half (22).

Use a T-10 bit to remove ground screw.

Gently wiggle front end to separate gear case assembly (34) from pinion of rotor assembly (25).

Lift stator from left housing cavity and carefully remove rotor assembly from the stator.

Lift old electronics assembly out of left housing half, paying attention to wire routing and trapping.

To install new Electronics Assembly:

Carefully place existing rotor (25) into stator of new electronics assembly.

Place stator/rotor and PCBA firmly and squarely into corresponding channels and cavities of left housing half (22).

Insert the rotor pinion into rear of gear case assembly, meshing the gears and seating the rotor bearing. At this point install two gear case screws (9), partially securing electronics assembly and gear case assembly. Put ground screw through ground wire terminal and install onto gear case. Be sure wires and ground wire are tucked back into left housing half.

Place LED assembly, on-off switch and battery terminal block firmly and squarely into the corresponding channels and cavities of the left housing half. Be sure all wires are routed and tucked down in channels and traps as illustrated above.

Re-install speed selector slide (23) and forward/reverse shuttle (17).

Carefully place right handle half onto left handle half. Check for any component interference or pinched wires. Re-install screws, housing clip and end cap. Check for proper functionality of on-off switch, forward/reverse shuttle and speed selector.

Install battery and check for the proper operation of tool.

Bit Holder on M12™ Products

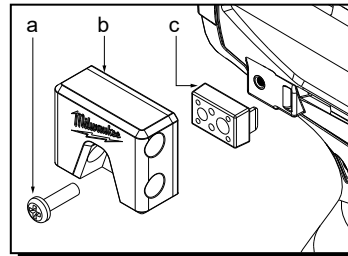

Bit Holder on M18™ Products

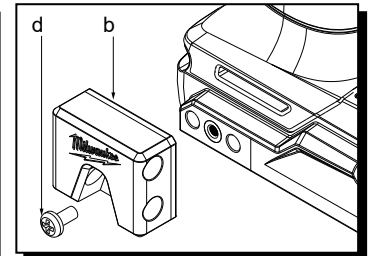

49-16-3697 BIT HOLDER (ACCESSORY)

FIG.	PART NO.	DESCRIPTION OF PART
a	06-82-3008	6-32 x 12.7mm Pan Hd. Phillips Screw (For M12™ Tools)
b	-----	Bit Holder
c	-----	Adapter (For M12™ Tools)
d	06-82-2500	6-32 x 7mm Pan Hd. Phillips Screw (For M18™ Tools)