

CST442

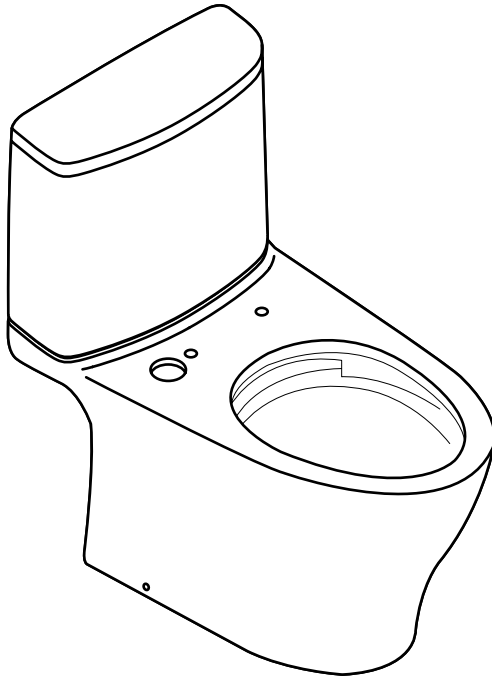

Warranty Registration and Inquiry

For product warranty registration, TOTO U.S.A. Inc. recommends online warranty registration. Please visit our web site <http://www.totousa.com>. If you have questions regarding warranty policy or coverage, please contact TOTO U.S.A. Inc., Customer Service Department, 1155 Southern Road, Morrow, GA 30260 (888) 295-8134 or (678) 466-1300 when calling from outside of U.S.A.

TABLE OF CONTENTS

Thanks for Choosing TOTO!2	Installation Procedure4
Common Tools Needed.....2	Maintenance Instructions.....8
Before Installation.....2	Warranty10
Included Parts3	Rough-In Dimensions29
Care and Cleaning.....3	

THANKS FOR CHOOSING TOTO!

The mission of TOTO is to provide the world with healthy, hygienic and more comfortable lifestyles. We design every product with the balance of form and function as a guiding principle. Congratulations on your choice.

COMMON TOOLS NEEDED

- | | |
|--|--|
| <ul style="list-style-type: none"> • 12" pipe wrench • 10" adjustable wrench • Carpenter's Level • Tape Measure • Plier | <ul style="list-style-type: none"> • Screwdriver • Putty Knife • Drill • 1¹/₆₄" drill bit for wood floor installation • 5¹/₁₆" drill bit for concrete/tile installation |
|--|--|

MATERIALS REQUIRED:

- | | |
|---|--|
| <ul style="list-style-type: none"> • Flexible Supply Tube / Connector • Supply Stop Valve | <ul style="list-style-type: none"> • Mounting (T) Bolts & Nuts (2pc) • Wax Ring / Seal |
|---|--|

BEFORE INSTALLATION

- Read instruction manual before installation.
- Maintenance and warranty information included in manual, DO NOT DISCARD.
- Locate water supply and drain pipe.

IMPORTANT!

For back-to-back installations, Tornado flushing systems require a WYE fitting incorporated into the toilet drain system. Please contact your builer/contractor for additional information prior to installation.

- Verify enough space is available for installation and unobstructed operation of equipment (doors opening/closing, etc...). Failure to do this beforehand may result in incorrect product installation and possible malfunction.
- Thoroughly flush the supply pipes of dirt and debris. Proceed to install the supply hose to the tank and make sure you do not damage the end connection of the hose.
- After installation, verify water and electricity are working properly.
- Gaps between the discharge pipe and the floor should be filled with mold-resistant silicone-based seal material (Mediseal).
- Minimum required water pressure (flowing): 7 PSI at 2.64 Gal/min (0.05 MPa at 10 L/min). Maximum water pressure (static): 108 PSI (0.75 MPa).

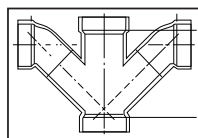

Double Combination WYE / 1/8 Bend
YES

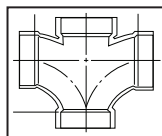

Double Sanitary Tee / Sanitary Cross
NO

INCLUDED PARTS AND INSTALLATION DIAGRAM

Please verify that all of the parts are included in the package:

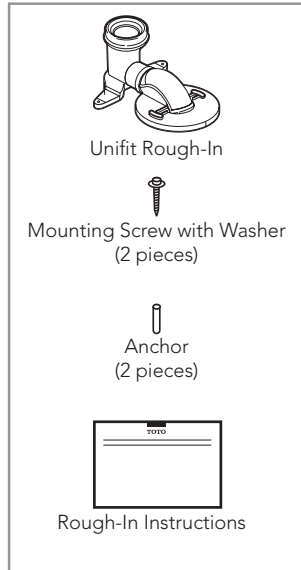
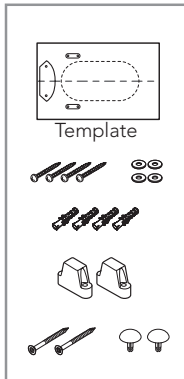
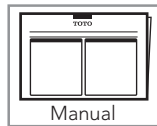
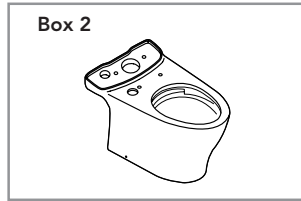
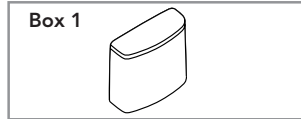
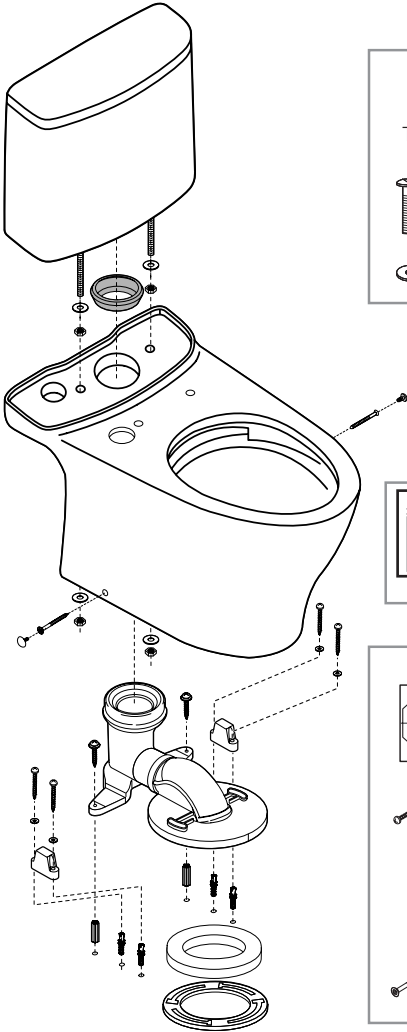

ENGLISH

CARE AND CLEANING

WARNING!
DO NOT USE IN-TANK BOWL CLEANERS.

The use of high concentration of chlorine or chlorine-related products can seriously damage fittings in the tank. This damage can cause leakage and serious property damage. TOTO shall not be responsible or liable for any tank fitting failure or damage caused by the use of in-tank bowl cleaners.

INSTALLATION PROCEDURE

1. Open the Unifit Rough-In packaging. Follow the Unifit Rough-In Installation instruction.
2. Place the template into position and follow its instructions to prepare for installing the toilet bowl.

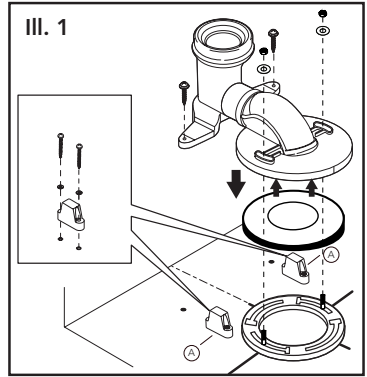

NOTICE Do not move the Unifit Rough-In on the Floor Flange after wax seal is set. If this notice is disregarded, discard the wax ring and replace with new wax ring.

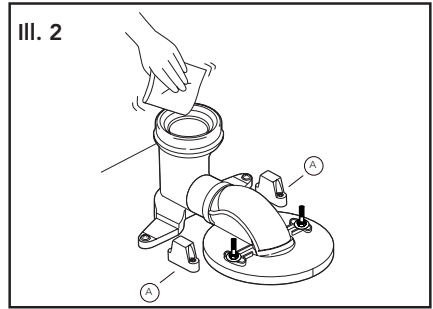

3. Place the toilet bowl over the Unifit Rough-In and align the holes on the side of the toilet to the lines marked "A" on the floor.

NOTICE Insert the toilet bowl all the way into position. If this notice is disregarded, leakage may result.

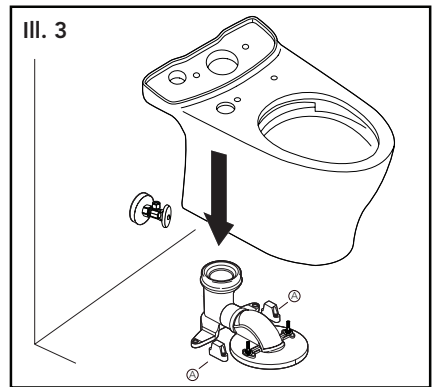

INSTALLATION PROCEDURE

- Align the toilet perpendicular to the back wall and parallel to side walls; it should not sit crooked or diagonal (see illustration 4).

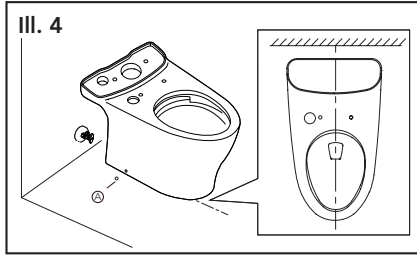

- Make sure it's aligned before securing.
- Install the side screws to the mounting blocks. Cover the screw head with the provided screw caps (see illustration 5).

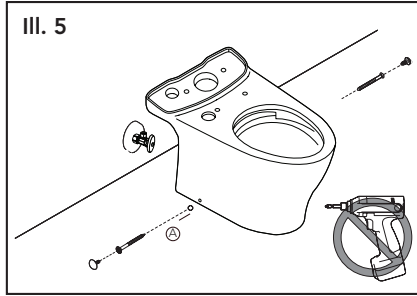

NOTE: THREE POINTS OF CONTACT

The toilet bowl has three points of contact, which will actually contact the bottom of the toilet tank when properly installed. The location of these points can be seen on the bowl at the tank receiving area. The three points are front left (1), front right (2), and back center (3). Recall these three points during the Toilet Tank installation.

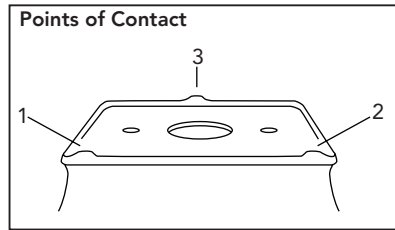

- Place the tank upside down onto some padding. Inspect the smaller fill valve nut and larger flush valve nut for a secure connection (see Illustration 6).

Try to tighten the nuts with your hands. If loose, tighten the nut hand tight and an additional 1/4 turn for the smaller fill valve nut and an additional 1/2 turn for the larger flush valve nut. Place the tank-to-bowl gasket onto the flush valve nut.

While pressing down, spread the gasket over the nut until the gasket touches the bottom of the tank. A slight gap between the tank bottom and the gasket is allowable.

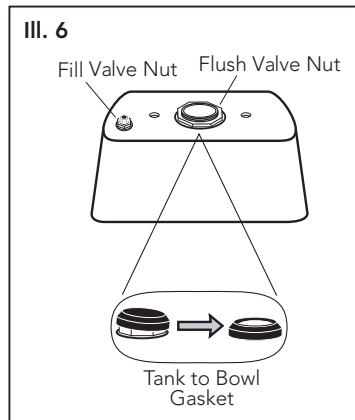

INSTALLATION PROCEDURE

8. Lay the tank down on its back. Place a rubber washer onto a brass bolt (see Illustration 7).

Reach inside the tank and position the bolt through one of the holes in the bottom of the tank. On the outside of the tank, place a metal washer and nut onto the bolt. Hold the bolt centered in the hole and tighten the nut finger tight. Turn the nut an additional 1/2 turn with a wrench. Repeat this process for the remaining hole in the tank.

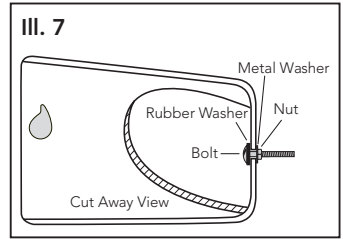

Pick up the tank and carefully guide the brass bolts to align the tank with the bowl. Attach a metal washer and the long nut to each bolt. Tighten the nuts finger tight and inspect that the tank is level (see Illustration 8).

Once level, tighten the bolts equally until the tank makes **THREE POINTS OF CONTACT** with the bowl.

9. Flush the water supply line for a few seconds to remove any debris that may enter the new fill valve. (For new home constructions and/or additions, flush the water supply line for more than a minute to help remove any residual PVC adhesives, solder flux, and/ or pipe sealants that were used for the new plumbing.)

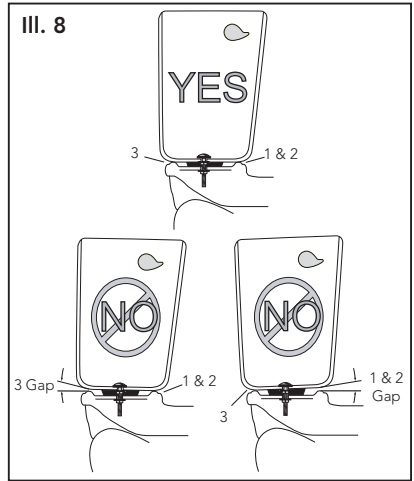

Connect the water supply line to the fill valve threads as seen at the bottom of toilet tank (see Illustration 9). Tighten this connection finger tight.

CAUTION: Avoid using a wrench to tighten the connection as you may damage the plastic threads and/or cause the fill valve to rotate inside the tank.

NOTE: The water supply pressure should be 20 to 80 psi static.

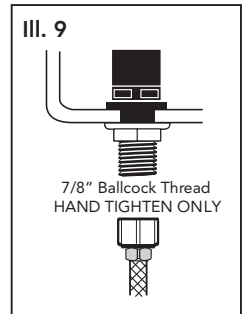

INSTALLATION PROCEDURE

10. No ballcock / fill valve adjustments are needed. The water will automatically stop at proper level. Flush the toilet several times. Check the valve for proper operation. Make sure that chain is not tangled and that the flapper arm is in its proper position.
11. Install the toilet tank lid onto the toilet tank top.
12. When installing the washlet main unit or standard toilet seat main unit, follow the instructions on the Installation Guide.
13. Once the installation is completed, proceed to verify the toilet unit for leaks.

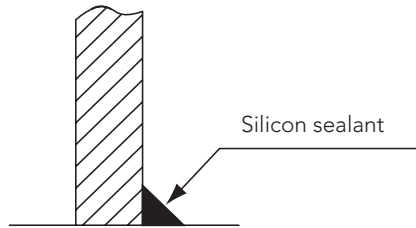
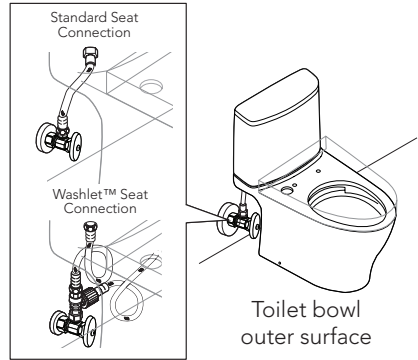

MAINTENANCE INSTRUCTIONS

Fill Valve Replacement Procedure

1. Shut off the water supply to the toilet.
2. Flush toilet and remove remaining water from tank with a sponge.
3. Remove the water supply connection at the fill valve.
4. Remove old fill valve and use damp sponge to clean inside tank.
5. Place new fill valve inside tank.
6. Thread mounting nut onto fill valve shank and tighten the nut.

NOTE: Do not over-tighten. Be sure to install fill valve in a position that does not interfere with the trip lever operation.

7. Connect water supply to fill valve shank and hand-tighten only.

NOTE: Do not overtighten. These are plastic parts. Never use pipe dope on any water supply connection.

8. Attach refill tube to fill valve nipple and clip other end of refill tube to the overflow pipe.
9. Turn water supply ON and check for leaks outside the tank.

NOTE: As water fills the tank, water is also directed into the overflow tube via the refill tube. This additional flow of water is critical to refilling your toilet's bowl. Once the water stops filling the tank, some residual drops of water may drip from the fill valve. This is NORMAL as these drops will subside.

ADJUSTING THE WATER LEVEL

Refer to the water level line stamp inside the tank.

1. The water level adjustment is located in the top end of the fill valve. Use a flathead screwdriver to make adjustments:
 - To raise the water level: turn the screwdriver clockwise, or towards the '+' indicator.
 - To lower the water level: turn the screwdriver counter-clockwise, or towards the '-' indicator.
2. Flush after each adjustment to check the water level. When satisfied with the water level, flush once more to verify.

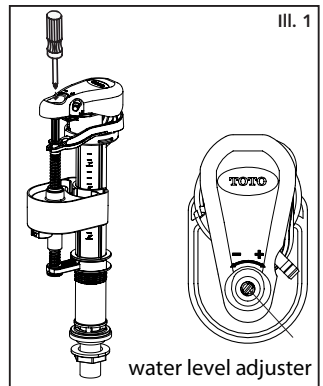

SERVICING THE FILL VALVE

NOTE: Due to water conditions in your area, the strainer may require periodic cleaning. An indication that the strainer requires service can be seen in a delayed fill cycle, intermittent fill cycle, or inadequate amount of water flow from the refill tube.

1. Snap off the top cover by pulling from under the tab (see illustration 1).
2. Pinch the tabs of the lever arm to allow its removal (see illustration 2).
3. Snap off the adjustable rod from the bracket (1) allowing the unit to slide to the bottom and remove the retainer tab by pulling as the arrow indicates (3) (see illustration 3).
4. Grab hold of the valve unit, twist 1/4 turn counterclockwise and pull the unit out (see illustration 4).
5. Unscrew nut of the diaphragm housing (see illustration 5).
6. Remove the diaphragm from its housing by carefully pulling the edge of the diaphragm (see illustration 6). Note the position of the diaphragm while removing.
7. Remove the strainer from the tube with needle nose pliers (see illustration 7). Use twisting motion while pulling to help with removal.
8. Rinse all parts under running water to clear any debris, residues or films. Reinstall all parts in reverse order. Turn the water ON and check for leaks and operation.

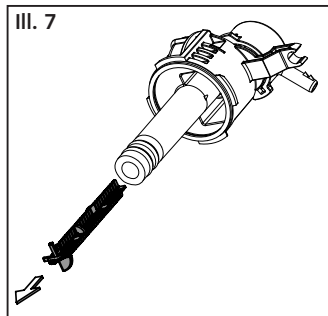
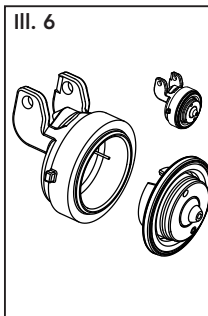
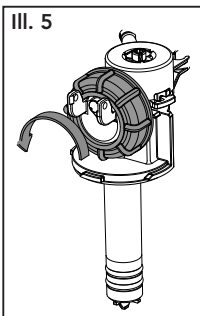
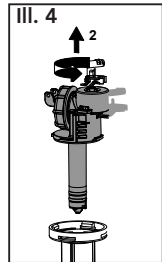
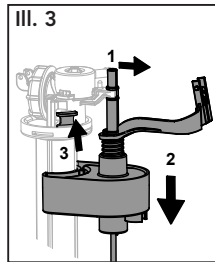
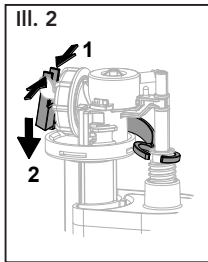
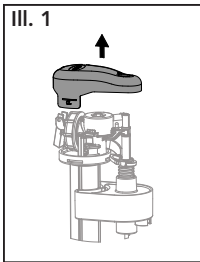

WARRANTY

ENGLISH

1. TOTO warrants its vitreous china products ("Product") to be free from defects in materials and workmanship during normal use when properly installed and serviced, for a period of one (1) year from date of purchase. This limited warranty is extended only to the ORIGINAL PURCHASER of the Product and is not transferable to any third party, including but not limited to any subsequent purchaser or owner of the Product. This warranty applies only to TOTO Product purchased and installed in North, Central and South America.
2. TOTO's obligations under this warranty are limited to repair, replacement or other appropriate adjustment, at TOTO's option, of the Product or parts found to be defective in normal use, provided that such Product was properly installed, used and serviced in accordance with instructions. TOTO reserves the right to make such inspections as may be necessary in order to determine the cause of the defect. TOTO will not charge for labor or parts in connection with warranty repairs or replacements. TOTO is not responsible for the cost of removal, return and/or reinstallation of the Product.
3. This warranty does not apply to the following items:
 - a. Damage or loss sustained in a natural calamity such as fire, earthquake, flood, thunder, electrical storm, etc.
 - b. Damage or loss resulting from any accident, unreasonable use, misuse, abuse, negligence, or improper care, cleaning, or maintenance of the Product.
 - c. Damage or loss resulting from sediments or foreign matter contained in a water system.
 - d. Damage or loss resulting from improper installation or from installation of the Product in a harsh and/or hazardous environment, or improper removal, repair or modification of the Product. (NOTE: Product model codes allow a maximum of 80 PSI. Check local codes or standards for requirements).
 - e. Damage or loss resulting from electrical surges or lightning strikes or other acts which are not the fault of TOTO or which the Product is not specified to tolerate.
 - f. Damage or loss resulting from normal and customary wear and tear, such as gloss reduction, scratching or fading over time due to use, cleaning practices or water or atmospheric conditions.
 - g. Tank flushing mechanisms of plastic or rubber moving parts.
 - h. Toilet seats of plastic, wood or metal.
4. In order for this limited warranty to be valid, proof of purchase is required. TOTO encourages warranty registration upon purchase to create a record of Product ownership at <http://www.totousa.com>. Product registration is completely voluntary and failure to register will not diminish your limited warranty rights.
5. THIS WARRANTY GIVES YOU SPECIFIC LEGAL RIGHTS. YOU MAY HAVE OTHER RIGHTS WHICH VARY FROM STATE TO STATE, PROVINCE TO PROVINCE OR COUNTRY TO COUNTRY.
6. To obtain warranty repair service under this warranty, you must take the Product or deliver it prepaid to a TOTO service facility together with proof of purchase (original sales receipt) and a letter stating the problem, or contact a TOTO distributor or products service contractor, or write directly to TOTO U.S.A., INC., 1155 Southern Road, Morrow, GA 30260 (678) 466-1300 or (888) 295-8134, if outside the U.S.A. If, because of the size of the Product or nature of the defect, the Product cannot be returned to TOTO, receipt by TOTO of written notice of the defect together with proof of purchase (original sales receipt) shall constitute delivery. In such case, TOTO may choose to repair the Product at the purchaser's location or pay to transport the Product to a service facility.

WARNING! TOTO shall not be responsible or liable for any failure of, or damage to, this Product caused by either chloramines in the treatment of public water supply or cleaners containing chlorine (calcium hypochlorite). NOTE: The use of a high concentrate chlorine or chlorine related products can seriously damage the fittings. This damage can cause leakage and serious property damage.

THIS WRITTEN WARRANTY IS THE ONLY WARRANTY MADE BY TOTO. REPAIR, REPLACEMENT OR OTHER APPROPRIATE ADJUSTMENT AS PROVIDED UNDER THIS WARRANTY SHALL BE THE EXCLUSIVE REMEDY AVAILABLE TO THE ORIGINAL PURCHASER. TOTO SHALL NOT BE RESPONSIBLE FOR LOSS OF THE PRODUCT OR FOR OTHER INCIDENTAL, SPECIAL OR CONSEQUENTIAL DAMAGES OR EXPENSES INCURRED BY THE ORIGINAL PURCHASER, OR FOR LABOR OR OTHER COSTS DUE TO INSTALLATION OR REMOVAL, OR COSTS OF REPAIRS BY OTHERS, OR FOR ANY OTHER EXPENSE NOT SPECIFICALLY STATED ABOVE. IN NO EVENT WILL TOTO'S RESPONSIBILITY EXCEED THE PURCHASE PRICE OF THE PRODUCT. EXCEPT TO THE EXTENT PROHIBITED BY APPLICABLE LAW, ANY IMPLIED WARRANTIES, INCLUDING THAT OF MERCHANTABILITY OR FITNESS FOR USE OR FOR A PARTICULAR PURPOSE, ARE EXPRESSLY DISCLAIMED. SOME STATES DO NOT ALLOW LIMITATIONS ON HOW LONG AN IMPLIED WARRANTY LASTS, OR THE EXCLUSION OR LIMITATION OF INCIDENTAL OR CONSEQUENTIAL DAMAGES, SO THE ABOVE LIMITATION AND EXCLUSION MAY NOT APPLY TO YOU.

NOTES

ROUGH-IN DIMENSIONS / BOSQUEJO / ROBINETTERIE BRUTE

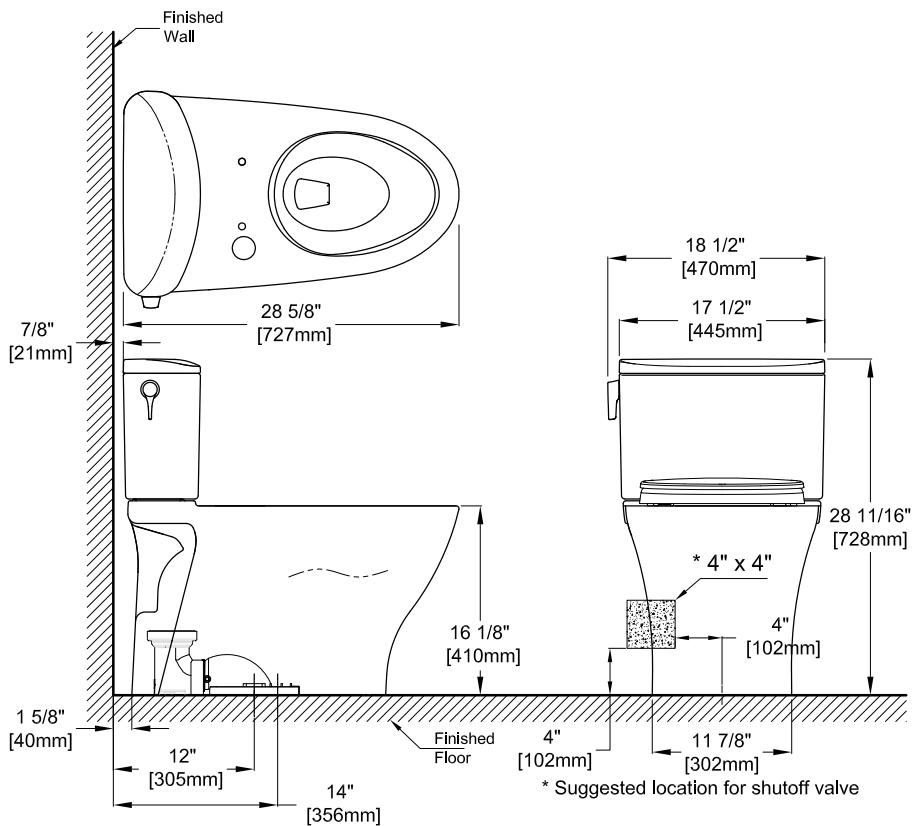

TOTO®

TOTO® U.S.A., Inc. 1155 Southern Road,
Morrow, Georgia 30260

Tel: 888-295-8134 Fax: 800-699-4889

www.totousa.com

0GU099

Rev Date: 1/19



Warranty Registration and Inquiry

For product warranty registration, TOTO U.S.A. Inc. recommends online warranty registration. Please visit our web site <http://www.totousa.com>. If you have questions regarding warranty policy or coverage, please contact TOTO U.S.A. Inc., Customer Service Department, 1155 Southern Road, Morrow, GA 30260 (888) 295-8134 or (678) 466-1300 when calling from outside of U.S.A.