

# RED LION®

**EN ENGLISH**

## SHALLOW WELL JET PUMP RL-SWJ Series Owner's Manual

**THIS PUMP IS DUAL VOLTAGE AND FACTORY SET FOR 230 VOLTS.  
SEE VOLTAGE SETTING INSTRUCTIONS TO SET FOR 115 VOLTS.**





### Table of Contents

Before Getting Started .....	2
Installation Checklist .....	3
Introduction.....	4
Voltage Setting Instructions .....	4
Materials and Tools Needed.....	5
Important Information.....	5
Quick Installation Guide .....	6
Detailed Installation Instructions .....	7-8
Typical Installations .....	9
Pump to Tank Installation .....	10
Wiring Instructions.....	11
Priming the Pump .....	12
Maintenance.....	13-14
Troubleshooting.....	14
Replacement Parts .....	15
Limited Warranty.....	16

## BEFORE GETTING STARTED

Read and follow safety instructions. Refer to product data plate(s) for additional operating instructions and specifications.

This is the safety alert symbol. When you see this  symbol on your pump or in this manual, look for one of the following signal words and be alert to the potential for personal injury or property damage if ignored:

 **DANGER** warns about hazards that will cause serious personal injury, death or major property damage if ignored.

 **WARNING** warns about hazards that can cause serious personal injury, death or major property damage if ignored.

 **CAUTION** warns about hazards that will or can cause minor personal injury or major property damage if ignored.

 **NOTICE** indicates special instructions which are important but not related to hazards. Carefully read and follow all safety instructions in this manual and on pump.

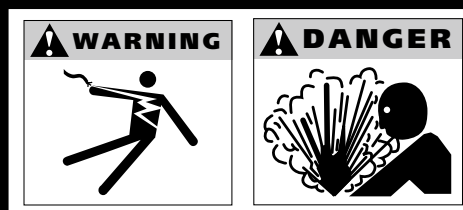

**BEFORE OPERATING OR INSTALLING THIS PUMP, READ THIS MANUAL AND FOLLOW ALL SAFETY RULES AND OPERATING INSTRUCTIONS.**

 **WARNING** READ AND FOLLOW ALL SAFETY INSTRUCTIONS.

 **WARNING ELECTRICAL PRECAUTIONS** - All wiring, electrical connections, and system grounding must comply with the National Electrical Code (NEC) and with any local codes and ordinances. Employ a licensed electrician.

 **WARNING FOR DUAL VOLTAGE MOTORS (115/230 V)** - Voltage change instructions are located in this manual.

 **NOTICE** The motor voltage is factory set at 230 V.

 **WARNING RISK OF ELECTRIC SHOCK**

- Have an electrician provide electrical power to motor.
- We recommend that a separate circuit be lead from the home electrical distribution panel, properly protected with a fuse or a circuit breaker.
- A ground fault interrupter (GFI) protected circuit is also recommended for use with any electrical device operating near water.
- For recommended cable size see Table 2.
- Motor must be grounded and terminal cover in place to reduce electrical shock hazard.
- Keep motor operating area as dry as possible.
- Always disconnect power before servicing.
- Not investigated for use in swimming pool areas.

 **WARNING 75 PSI PRESSURE RELIEF VALVE RECOMMENDED**

This pump is capable of producing high pressure. Installing a 75 psi pressure relief valve is highly recommended.

# INSTALLATION CHECKLIST

This checklist has been provided for your convenience. If a step was missed, ensure power has been shut off at the breaker and completely relieve pressure from the water system before continuing to work on the system.

## **⚠ WARNING 75 PSI PRESSURE RELIEF VALVE RECOMMENDED**

This pump is capable of producing high pressure. Installing a 75 psi pressure relief valve is highly recommended.

Model #: \_\_\_\_\_

Serial #: \_\_\_\_\_

Date purchased: \_\_\_\_\_

Location purchased: \_\_\_\_\_

**KEEP THIS MANUAL ACCESSIBLE FOR FUTURE REFERENCE.**

✓	Description
	Voltage setting on pump verified and set to match voltage on the circuit breaker
	Foot valve (for drilled wells) or check valve (for driven well) installed
	Wiring and electrical connected by licensed electrician
	Pump intake connected to piping in well
	Well seal in place
	Pump discharge connected to tank and service line
	Tank pressure checked and charged to 28 psi
	All joints sealed with PVC cement, PTFE tape or heat and clamps
	All connections checked for leaks
	Pressure relief valve installed
	All other accessories installed: drain cock, shut-off valve, pressure gauge (optional)
	Breaker turned on
	Pump primed
	Model number and serial number recorded in this manual
	Receipt stapled to manual

## INTRODUCTION

The shallow well jet pump is ideal for the supply of fresh water to rural homes, farms, and cabins. This pump is suitable for installations where the vertical distance from the pump to the water level does not exceed 25 ft (7.6 m), including drawdown (less at high altitudes). In offset installation, friction losses in the suction pipe must be taken into consideration (refer to **Table 1, Friction Loss**).

This instruction sheet provides you with the information required to safely own and operate your product. Retain these instructions for future reference.

The product you have purchased is of the highest quality workmanship and material, and has been engineered to give you long and reliable service. This product has been carefully tested, inspected, and packaged to ensure safe delivery and operation. Please examine your item(s) carefully to ensure that no damage occurred during shipment. If damage has occurred, please contact the place of purchase. They will assist you in replacement or repair, if required.

**READ THESE INSTRUCTIONS CAREFULLY BEFORE ATTEMPTING TO INSTALL, OPERATE OR SERVICE YOUR PRODUCT. KNOW THE PRODUCT'S APPLICATION, LIMITATIONS, AND POTENTIAL HAZARDS. PROTECT YOURSELF AND OTHERS BY OBSERVING ALL SAFETY INFORMATION. FAILURE TO COMPLY WITH THESE INSTRUCTIONS COULD RESULT IN PERSONAL INJURY AND/OR PROPERTY DAMAGE!**

## VOLTAGE SETTING INSTRUCTIONS

To change the pump voltage from the factory setting of 230 Volts, a qualified electrician should:

1. Disconnect power supply to pump
2. Remove the cover from the motor terminal box
3. Slide the voltage switch from 230 V to 115 V, as shown in Figure 2
4. Reassemble the terminal box cover

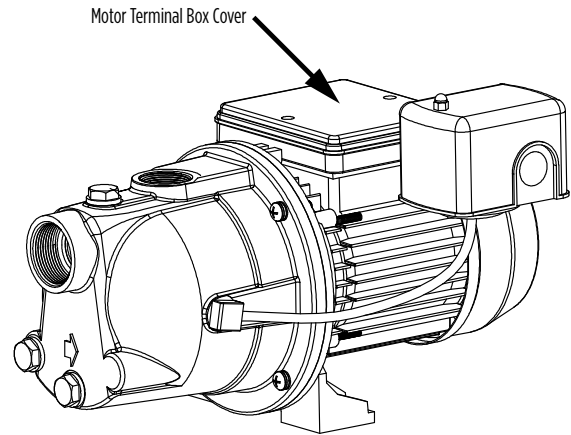

Figure 1

The motor's switch is set for 230 V:



The motor's switch is set for 115 V:



Place screwdriver where indicated and slide left or right.

Figure 2 - VOLTAGE SWITCH

## MATERIALS AND TOOLS NEEDED

### MATERIALS NEEDED

#### Pipe Joints

- One roll of PTFE tape
- One can PVC primer
- One can PVC cement
- Steel clamps (optional)

#### Drilled Wells (driven well materials are listed separately)

- One 1-1/4" foot valve (not needed for driven wells)
- One 1-1/4" PVC pipe (to attach to foot valve – needed for shallow well only)
- Rigid 1-1/4" PVC pipe and couplings to reach from bottom of well to pump
- One 1-1/4" male PVC adapter (for discharge opening)
- Well seal with vent tube
- One 1-1/4" PVC 90° elbow (to join piping from well to pump)
- One 1-1/4" male galvanized adapter (for suction opening)

#### Driven Wells

- Well point (more than one may be needed)
- 1-1/4" galvanized pipe from bottom of well to the top of well plus 1 ft (30 cm) (if more than one well point is needed, additional piping and elbows will be needed to join the well points together)
- One 1-1/4" galvanized 90° elbow
- One 1-1/4" galvanized nipple
- One 1-1/4" check valve
- One 1-1/4" male PVC adapter
- One 1-1/4" male galvanized adapter
- 1-1/4" PVC pipe measured from adapter connected to pump to check valve
- Restrictor valve (connected after the elbow on the pump discharge)
- Low pressure cut-off pressure switch (recommended)

#### Pump to Tank Installation

- One male PVC adapter (attached to tank) – the tank fitting size depends on the system connect on the tank
- One tank tee – size should be the same as the adapter above
- One 1" PVC elbow
- PVC piping to fit from tank tee to the elbow on the pumps discharge and to join the service line
- High pressure safety relief valve (attached to the tank tee)
- One 1/2" drain cock (attached to the tank tee)

### TOOLS NEEDED

- Round file
- Pipe clamp
- Pipe wrench or crescent wrench
- Slotted screwdriver
- Cross-head screwdriver
- Hacksaw or reciprocating saw
- Heat gun (optional)

## IMPORTANT INFORMATION

### JOINING PIPE FITTINGS

Follow the fitting guidelines below for all attachments unless otherwise specified.

### PVC PIPE FITTINGS

When joining two PVC joints together (such as joining an adapter to a PVC pipe) always use PVC primer to clean both pieces– applying the primer to the inside of one joint and the outside of the other joint so the primed areas meet. Select Method 1, 2 or 3 to affix the joints. When tightening PVC, tighten securely but do not over-tighten or you could break the fitting.

**Method 1 – PTFE tape:** Wrap PTFE tape tightly around the male threads. Start wrapping the threads at the end of the pipe, keeping tension on the tape. Do not let the tape hang over the edge of the adapter. Wrap in the direction of the threads starting from the end for the full length of the adapter. Overlap each wrap about 70%.

**Method 2 – Using PVC cement:** Apply PVC cement to the areas that were just primed and join the two pieces together. Twist to the right and back to the left to help imbed the cement between the pieces.

**Method 3 – Using heat and clamps:** Add two steel clamps to the largest fitting before joining the fittings. Heat the largest fitting with a heat gun (follow all safety instructions in the heat gun manual). This will shrink the fitting, bonding it to the smaller joint. Once the joint has cooled down, tighten the clamps with a screwdriver.

### METAL PIPE FITTINGS

Use PTFE tape or thread compound to coat the threadings.

**CHECK TO ENSURE THE JOINTS ARE AIRTIGHT.  
EVEN A PINHOLE CAN PREVENT PROPER OPERATION OF THE PUMP.**

### SUCTION AND PRESSURE PIPE

It is recommended that only new, clean 1-1/4" pipe or hose be used. If the pump is installed any appreciable distance away from the source of water, the suction pipe should be increased to 1-1/2". Horizontal lengths of pipe must gradually slope upward from the source of water to the pump to avoid air pockets in the line. Thread compound should be used on all pipe joints and connections should be thoroughly tightened. **A foot valve or check valve must be installed** and its operation should be checked since a leak will prevent proper operation of the system. Make sure the foot valve is located so that it will be submerged at all times. If a sandpoint or driven well is used, install a check valve next to the pump suction instead of the foot valve (see **Typical Installations** Figure 5). All installations must have a foot valve or a check valve in the suction pipe.

## QUICK INSTALLATION GUIDE (Replacing an Existing Pump)

This quick installation guide assumes you will be cutting the existing pump free from the plumbing. More detailed instructions are provided in the **Detailed Installation Instructions**.

### **⚠ WARNING DO NOT RUN THE PUMP BEFORE PRIMING IT; THE SEAL AND IMPELLER COULD BE PERMANENTLY DAMAGED**

1. Ensure power has been shut off at the breaker before proceeding.
2. **This pump is dual voltage (115/230 V)! Inspect the voltage wiring on the pump and ensure it matches the voltage on the breaker before continuing with the installation (see Voltage Setting Instructions).**
3. Completely relieve pressure from the water system before working on the water system. Open the faucet nearest the tank and allow the water to drain until the tank is empty.
4. Disconnect wiring from the pressure switch to the electrical source.
5. Using a hacksaw or reciprocating saw, cut all PVC piping as close to the old pump as possible at both the suction and discharge openings. Ensure the pipe from the well and the pipe from the tank are clean and free of any pipe shavings or pieces as these could get into the pump and damage the impeller.
6. Set the new pump in place.
7. Seal the threads on the suction opening on the pump with PTFE tape or thread compound and insert the 1-1/4" male galvanized adapter into the suction opening. Tighten securely but do not over-tighten as this could crack the fitting.
8. Attach the 1-1/4" PVC pipe from the well to the male adapter (additional fittings may need to be added). **Check to ensure the joints are airtight. Even a pinhole can prevent proper operation of the pump.**
9. Seal the threads of the discharge opening on the pump with PTFE tape or thread compound and insert the 1" male PVC adapter into the discharge opening. Tighten securely but do not over-tighten as this could crack the fitting.
10. Attach the 1" PVC pipe from the tank to the 1" male PVC adapter (additional fitting may need to be added). **Check to ensure the joints are airtight. Even a pinhole can prevent proper operation of the pump.**
11. A pressure gauge is not supplied with the pump. It should be installed into the 1/8" NPT hole on the front of the casing on the opposite side of the pressure switch (see **Typical Installations** Figures 3, 4, 5, or 6).
12. An electrician should be employed to do the wiring and connect the electrical service to the pump (see **Wiring Instructions**).
13. Prime the pump (see **Priming Instructions**).
14. Verify everything has been completed using the **Installation Checklist** provided in this manual.

# DETAILED INSTALLATION INSTRUCTIONS

## **⚠ WARNING DO NOT RUN THE PUMP BEFORE PRIMING IT; THE SEAL AND IMPELLER COULD BE PERMANENTLY DAMAGED**

Before proceeding, ensure power has been shut off at the breaker. If this is replacing an existing pump, completely relieve pressure from the water system before working on the water system. Open the faucet nearest the tank and allow the water to drain until the tank is empty.

### SHALLOW WELL APPLICATION

**(for pumping depths down to 25 ft [7.6 m])**

Shallow well installations use only a single pipe connecting the pump to the water supply. This pump can be used for drilled wells (see Figures 3, 4 or 6) or driven wells (see Figure 5). Drilled wells are holes drilled into the ground by professional well drillers using a large rig. Driven wells use well points (also known as sand points), which is a long pointed tube with a screen that allows water to enter the pipe but keeps out sand and sediment. The water level in a driven well is fairly high or near ground level (maximum 30 ft [9.1 m]). Continue with the appropriate shallow well installation.

### DRILLED WELLS (with foot valve)

1. Measure from the bottom of the well to the top of the well and subtract 5 ft (1.5 m). This is the length of 1-1/4" rigid PVC pipe and couplings you will need from the bottom of the well to the first elbow. Cut the pipe and use a round file to smooth the pipe cutting. Ensure the pipe is clean and free of any pipe shavings or pieces as these could get into the pump and damage the impeller. The remainder of the pipe will be used to connect the pump to the well.
2. Attach the 1-1/4" male PVC adapter to one end of the rigid PVC pipe and attach the adapter to the foot valve. **Check to ensure the joints are airtight. Even a pinhole can prevent proper operation of the pump.**
3. Firmly clamp the unfinished end of the pipe with a pipe clamp 1 ft (30 cm) from the top of the pipe. This will prevent the pipe from dropping to the bottom of the well. Lower this section into the well foot valve first.
4. On the end protruding from the well, which is held in place with the pipe clamp, insert the well seal and have the pipe protrude 1 ft (30 cm) outside of the well seal. If you have measured correctly, the foot valve will be suspended 4 ft (1.2 m) from the bottom of the well. This will ensure sand and sediment doesn't get drawn into the system. Install a well vent tube in the well cap.
5. Attach the end of the pipe securely to a 1-1/4" PVC 90° elbow.
6. Install the pump in a clean, dry, and ventilated location which provides adequate room for services and protection from freezing temperatures. It should be bolted to a good foundation, preferably concrete, and provided with adequate drainage. Locating the pump as close as possible to the water source reduces the friction in the suction pipe and will provide maximum performance.
7. A pressure gauge is not supplied with the pump. It should be installed into the 1/8" NPT hole on the front of the casing on the opposite side of the pressure switch (see **Typical Installations** Figures 3, 4 or 6).
8. Attach a 1-1/4" male galvanized adapter into the suction inlet. Do not over-tighten as this could crack the fitting.
9. Use the remainder of the PVC pipe from Step 4. Smooth the pipe cutting using a round file. Ensure the pipe is clean and free of any pipe shavings or pieces as these could get into the pump and damage the impeller; connect one end of the pipe to the adapter attached to the suction inlet. **Check thoroughly for any leaks. All connections and joints must be airtight. A small pinhole leak can prevent the pump from operating properly.**
10. Follow the **Pump to Tank Installation** procedures.
11. Verify everything has been completed using the **Installation Checklist** provided in this manual.



# DETAILED INSTALLATION INSTRUCTIONS

## DRIVEN WELL (with check valve and well point)

1. Drive the well point into the ground according to the instructions that come with the well point. It must be deep enough to bore through the water bearing formation below the water table but should not exceed 25 ft (7.6 m) in depth. An individual well point may not supply the amount of water needed. Sometimes it is necessary to use more than one well point to increase the water supply. The two separate well points can be jointed together using additional piping and a cross joint (see Figure 5).
2. Plan to have at least 1 ft (30 cm) of pipe protruding from the ground. The rise pipe should be galvanized pipe in approximately 5 ft (1.5 m) sections. This makes it easier to hand drive. Use as much pipe and as many drive couplings as it takes to both reach the water and account for the 1 ft (30 cm) of pipe protruding from the ground.
3. Attach a 1-1/4" galvanized elbow onto the pipe protruding from the ground.
4. Attach a 1-1/4" galvanized nipple to the 1-1/4" galvanized elbow.
5. Attach a 1-1/4" check valve to the 1-1/4" galvanized nipple.
6. Attach a 1-1/4" male PVC adapter to the 1-1/4" check valve.
7. Install the pump in a clean, dry, and ventilated location which provides adequate room for services and protection from freezing temperatures. It should be bolted to a good foundation, preferably concrete, and provided with adequate drainage. Locating the pump as close as possible to the water source reduces the friction in the suction pipe and will provide maximum performance.
8. A pressure gauge is not supplied with the pump. It should be installed into the 1/8" NPT hole on the front of the casing on the opposite side of the pressure switch (see **Typical Installations** Figure 5).
9. Attach a 1-1/4" male galvanized adapter into the pump suction inlet. Do not over-tighten as this could crack the fitting. Measure from this adapter to the check valve that was installed in Step 6. Cut 1-1/4" PVC pipe to this measurement. Using a round file, smooth the pipe cutting. Ensure the pipe is clean and free of any pipe shavings or pieces as these could get into the pump and may damage the impeller. Attach the 1-1/4" PVC pipe to the adapter and then to the check valve. **Check thoroughly for any leaks. All connections and joints must be airtight. A pinhole leak can prevent proper operation of the pump.**
10. Driven wells water levels may, at times, be too low to pump up. To prevent damage to the pump, have an electrician replace the pressure switch with a low pressure cut-off switch.
11. Follow the **Pump to Tank Installation** procedures.
12. Verify everything has been completed using the **Installation Checklist** provided in this manual.



# TYPICAL INSTALLATIONS

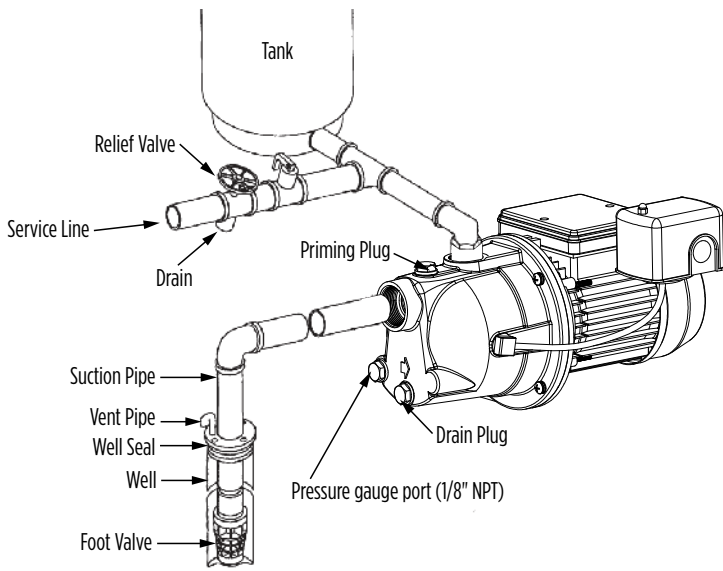

**Figure 3 - SHALLOW WELL**  
(with foot valve)

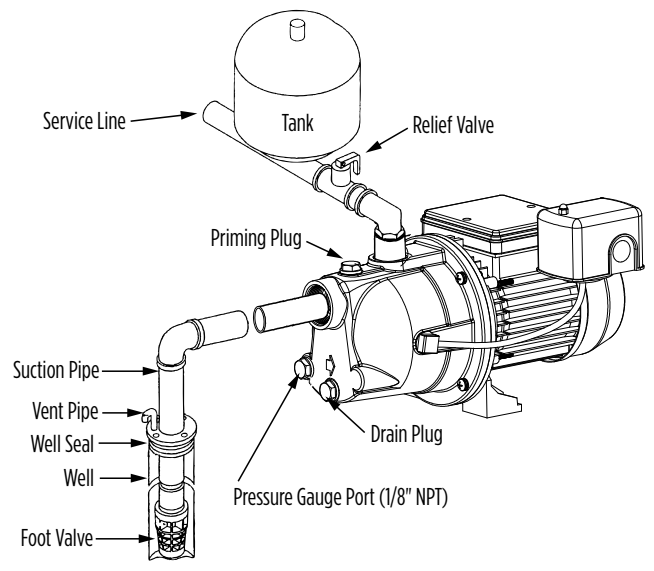

**Figure 4 - SHALLOW WELL, INLINE TANK**  
(with foot valve)

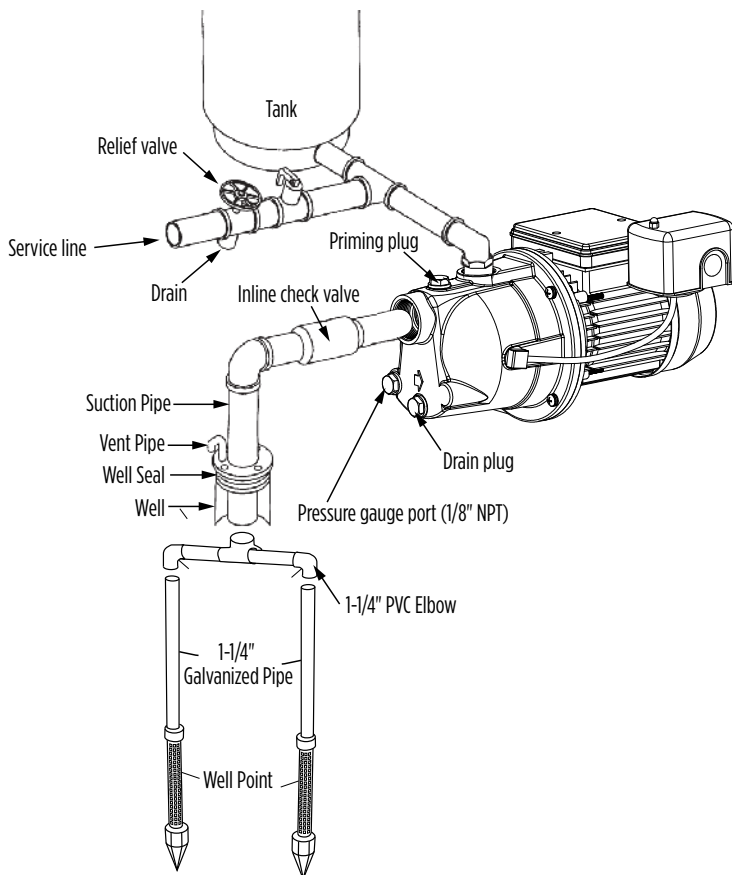

**Figure 5 - SHALLOW WELL**  
(with inline check valve)

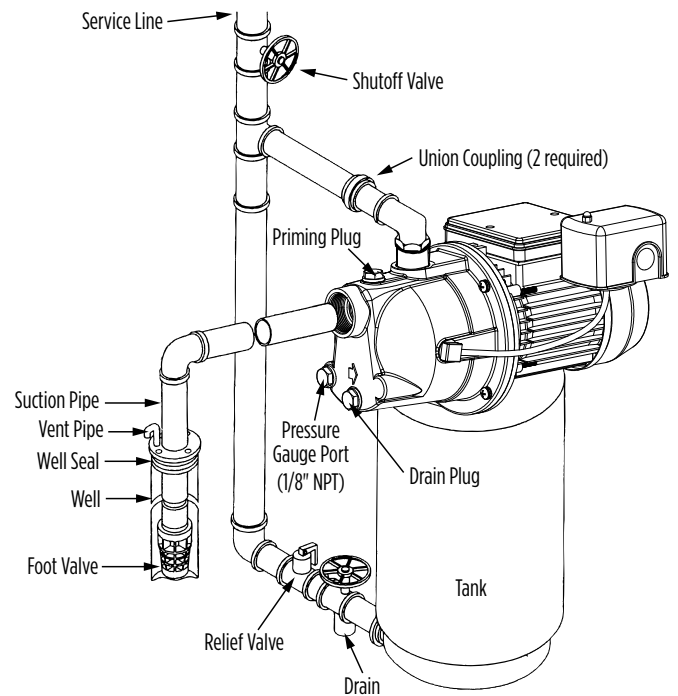

**Figure 6 - SHALLOW WELL, TANK MOUNTED SYSTEM**  
(with foot valve)

# PUMP TO TANK INSTALLATION

Red Lion® recommends using pre-charged diaphragm tanks. Instructions for connecting the pump to a diaphragm tank have been provided for your convenience.

If a non-diaphragm tank is used in the pressure system, an air volume control must be used to maintain an air cushion in the pressure tank. If not, air in the tank will gradually be absorbed by water, causing the tank to water log and the pump to short cycle (turn off and on frequently). This greatly shortens the life of the motor. An air volume control will provide the right air/water ratio and prevent water logging. Refer to the pressure tank owner's manual for instructions.

**NOTE:** A check valve should never be installed between the pump and the tank.

Before proceeding, ensure power has been shut off at the breaker. If this is replacing an existing pump, completely relieve pressure from the water system before working on the water system. Open the faucet nearest the tank and allow the water to drain until the tank is empty.

## ⚠ WARNING

### 75 PSI PRESSURE RELIEF VALVE RECOMMENDED

This pump is capable of producing high pressure. Installing a 75 psi pressure relief valve is highly recommended.

1. The discharge pipe from the pump to the tank should be as short and direct as possible and should be the same size as the discharge outlet. You should have already attached a 1" PVC adapter to the discharge opening of the pump.
2. Attach a PVC 90° elbow to the adapter.
3. Attach a male PVC adapter to the tank. The tank fitting size depends on the system connect on the tank.
4. Install a 1" brass tank tee to the tank adapter.
5. Measure the distance from the tank tee to the elbow (or restrictor valve) on the pump's discharge and attach 1" PVC piping to fit.
6. Attach accessories to the brass tee such as restrictor valve (recommended for well point installations), high pressure safety relief valve (recommended for all installations), and drain cock. Ensure the high pressure safety relief valve's location is near the discharge of the pump, in an area with adequate drainage. Be sure to direct the valve so that any water flow will not spray toward the pump or any other electrical devices.
7. Add piping and coupling to join up the service line. The size of the service line required is governed entirely by the amount of water needed and the length of the pipe. The pipe selected should be large enough so that the friction loss (determined from **Table 1, Friction Loss for Plastic Pipe**) will never exceed 20 ft (6 m) of head.
8. Remove the PVC cap on the air valve on the tank.

9. Check the tank pre-charge with a tire gauge. It should be equal to 2 psi below the pressure switch cut-in setting (the pressure at which the pump will start). For this pump that is 30 psi, therefore the pre-charge pressure should be adjusted to 28 psi. Use a tire pump or air compressor to charge the tank, if necessary.
10. Replace and tighten the PVC cap on the air valve.
11. See **Typical Installations** for examples of different pump/tank configurations.
12. Verify everything has been completed using the **Installation Checklist** provided in this manual.

**Table 1 - FRICTION LOSS FOR PLASTIC PIPE\***

Loss of head in feet due to friction per 100 feet of pipe.

Nominal Pipe Size U.S. GPM	3/4"	1"	1-1/4"	1-1/2"	2"
4	3.75	1.15	0.30	0.14	-
5	5.66	1.75	0.46	0.22	-
6	7.95	2.45	0.65	0.31	-
7	10.60	3.25	0.86	0.41	-
8	13.50	4.16	1.10	0.52	-
9	16.80	5.17	1.35	0.65	-
10	20.40	6.31	1.67	0.79	0.25
11	24.40	7.58	1.98	0.95	0.27
12	28.60	8.85	2.33	1.10	0.32
14	38.00	11.80	3.10	1.46	0.43
16	48.60	15.10	3.96	1.87	0.55
18	60.50	18.70	4.93	2.33	0.69
20	73.50	22.80	6.00	2.83	0.84

Loss of head in meters, due to friction per 100 meters of pipe.

Nominal Pipe Size L/Min.	20mm	25mm	32mm	40mm	50mm
15	3.7	1.15	0.30	0.13	-
20	5.3	1.64	0.43	0.19	-
25	7.1	2.18	0.56	0.27	-
30	13.5	4.13	1.08	0.49	-
35	16.3	5.00	1.31	0.61	-
40	23.5	7.30	1.90	0.88	0.25
45	28.3	8.74	2.31	1.07	0.29
50	34.2	10.60	2.79	1.32	0.38
55	40.7	12.60	3.32	1.56	0.46
60	48.1	14.90	3.92	1.85	0.54
65	55.7	17.30	4.45	2.15	0.63
70	63.8	19.70	5.20	2.46	0.73
75	72.2	22.40	5.89	2.78	0.83

\*For galvanized pipe, double the figures.

# WIRING INSTRUCTIONS

## **⚠ WARNING ELECTRICAL PRECAUTIONS**

All wiring, electrical connections, and system grounding must comply with the National Electrical Code (NEC) and with any local codes and ordinances. Employ a licensed electrician.

## **⚠ WARNING RISK OF ELECTRICAL SHOCK**

Before servicing motor-operated equipment, shut off the power at the main electrical panel and disconnect the power supply from motor and accessories. Use safe working practices during servicing of equipment.

## WIRING

An electrician should be employed to do the wiring and connect the electrical service to the pump. The pressure switch is wired to the motor at the factory and the voltage for which the motor is wired is indicated by the voltage change device which is found under the wiring access cover located on the back of the pump. Make sure the motor is wired for the same voltage as the power supply. Refer to the inside of the wiring access cover or this manual for voltage changing instructions. The power lines should be connected to the pressure switch terminals marked "line" (Figure 7). It is recommended that a separate circuit be led from the distribution panel to the pump unit. A ground fault interrupter (GFI) protected circuit should be used for all electrical devices operating near water. Install a properly fused disconnect switch in the line and make certain the wiring is adequately sized and well insulated. **Undersized wire between the motor and the power source will adversely limit the starting and load carrying abilities of the motor.** Minimum wire sizes for motor branch circuits are recommended (see Table 2). For added safety, the pump and motor should be grounded to the well casing, if metal, or the ground in the distribution panel.

Table 2 - MAXIMUM WIRE LENGTH

MOTOR		WIRE GAUGE (AWG)				
HP	Volts	25 ft (8 m)	50 ft (15 m)	100 ft (30 m)	150 ft (46 m)	200 ft (61 m)
1/2	115	14	14	12	10	8
	230	14	14	14	14	14
3/4	115	14	14	10	8	8
	230	14	14	14	14	12
1	115	14	12	10	8	6
	230	14	14	14	14	12

Based on an approximate 3% voltage drop.

Figure 7 - ELECTRICAL CONNECTIONS

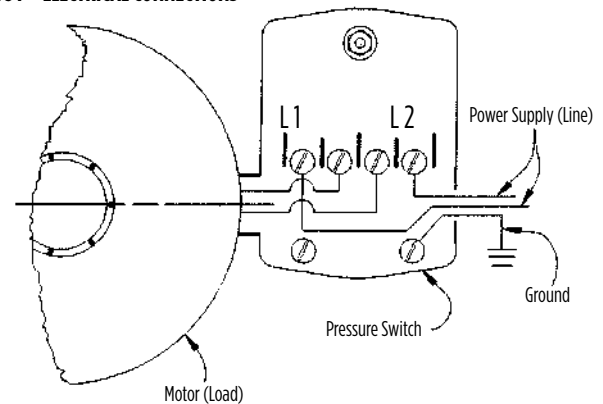

## PRIMING THE PUMP

**⚠ WARNING** DO NOT RUN THE PUMP BEFORE PRIMING IT; THE SEAL AND IMPELLER COULD BE PERMANENTLY DAMAGED.

**NOTE:** You will need enough water to fill the suction line(s) and casing. Priming time depends on the distance from the water source to the pump (5-15 minutes).

### USING AN INLINE CHECK VALVE

1. Open the discharge valve on service line and nearby tap to monitor water flow.
2. With a wrench, remove the priming plug.
3. Pour clean water through the priming plug opening.
4. Continue filling the pump until water flows out of the priming hole.
5. Reinstall the priming plug, hand tighten.
6. Start the pump. If a tap is visible, you may see a short discharge of water that will last 5-10 seconds.
7. Run the pump for 2 minutes and then shut it off. Remove the priming plug.
8. You have completed the first priming cycle, consisting of Steps 3 to 7. This process will have to be repeated from 2 to 6 times, depending on the length of your suction line. (Approximately one priming cycle for every 5 ft [1.5 m] of suction line.) You will know when to stop because the pump will begin to pump water continuously.
9. Once the pump begins pumping water continuously, firmly tighten the priming plug with a wrench.
10. If the pump does not draw water within 8 tries, shut it off and check the suction line for leaks.

### USING A FOOT VALVE

1. Open the discharge valve on the service line and nearby tap to monitor water flow.
2. With a wrench, remove the priming plug.
3. Pour clean water through the priming plug opening. You will need approximately 1 quart (1 liter) of water for every 3 ft (1 m) of suction line.  
**NOTE:** If you are unable to fill the suction line, please follow the directions for an inline check valve.
4. Continue filling the pump until water flows out of the priming hole.
5. Reinstall the priming plug, hand tighten.
6. Start the pump. If the pump is primed correctly it should start pumping water immediately.
7. If within 2 minutes water is not being pumped continuously, stop the pump. Remove the priming plug. Repeat Steps 3 through 7. If this does not work, stop the pump and check the suction line for leaks.
8. Once the pump begins pumping water continuously, firmly tighten the priming plug with a wrench.

# MAINTENANCE

## **⚠ WARNING RISK OF ELECTRICAL SHOCK**

Before servicing motor-operated equipment, shut off the power at the main electrical panel and disconnect the power supply from motor and accessories. Use safe working practices during servicing of equipment.

## PERFORM INSPECTIONS MONTHLY

1. Ensure pump is still securely bolted to the foundation.
2. To avoid any fire hazards, ensure that there is adequate clearance from any combustible materials, shelving or cabinets. Ensure there are no leaves or debris near the pump.
3. Ensure that the motor is securely wired into a proper GFCI-protected circuit. Test the GFCI periodically by pressing the test switch when the pump is operating. This should shut off the pump. If the GFCI does not shut the pump off, have an electrician replace the GFCI as soon as possible. Remember to reset the GFCI by pressing the reset switch.
4. Look for any signs of leaks in pipes. Replace or repair, if necessary.
5. Clean the exterior of the pump, if needed, with a solution of vinegar and water.

## DRAINING

Should the unit be subject to freezing, it will be necessary to drain the pump and tank. To do this, shut off the power to the pump at the main electrical panel. Open a tap in the water system to release the pressure. Remove the drain and priming plugs from the pump casing. Remove the pressure tank drain plug (if so equipped). Allow ample time for the system to drain before reinstalling the plugs.

## LUBRICATION

The pump requires none.

## REPLACING MECHANICAL SEAL (See Figure 8)

### **⚠ CAUTION ONLY DULY QUALIFIED PERSONS SHOULD PERFORM MAINTENANCE ON ELECTRICAL AND/OR MECHANICAL DEVICES.**

#### Disassembly:

1. Shut off the power to the pump at the main service panel and disconnect the power supply from motor.
2. Open a tap in the water system to release the pressure.
3. Remove the drain and fill plugs to allow the pump to drain.
4. Remove the bolts (1) and remove casing (2).
5. Remove fan shroud fasteners from the motor and remove the fan shroud (3).

### **⚠ CAUTION Care must be taken not to damage the motor fan or shroud.**

6. Remove the impeller (4) by firmly holding on to the motor fan (5) and turn the impeller in a clockwise direction.
7. Slip rotating seal (9) off the shaft.
8. Remove motor tie bolts and remove motor (6) from adapter (7) by slightly tapping end of motor shaft with a mallet.
9. Remove the adapter plate and the O-ring.

#### Reassembly:

1. Clean all parts thoroughly before assembling.
2. Lightly lubricate (soapy water) the rubber cap on the ceramic seal (8) and push it into the adapter (7) using thumbs only. Make sure the smooth surface of the ceramic seat faces outward.

### **⚠ CAUTION Do not use petroleum-based cleaners or lubricants.**

### **⚠ CAUTION Care must be taken not to contaminate the ceramic seal face.**

**NOTE:** If the pump will remain out of service for longer than one week, the seal components must be installed dry (no lubrication).

3. Reassemble the motor (6) to the adapter. Align the tabs of the adapter plate with the slot at the bottom of the motor housing.

- Lubricate the rubber components of the rotating seal (9) (soapy water) and slip it on to the shaft with the 'carbon' ring towards the ceramic seat. Replace the impeller (6) and the diffuser (4).

**⚠ CAUTION** Care must be taken not to contaminate the ceramic seal face.

- Replace the impeller (4) and the shroud with fasteners. Lubricate and replace the O-ring.
- Replace the casing (2), making sure that O-ring is not damaged and is in place.
- Replace drain and fill plugs.
- Reconnect power.
- Prime the pump.

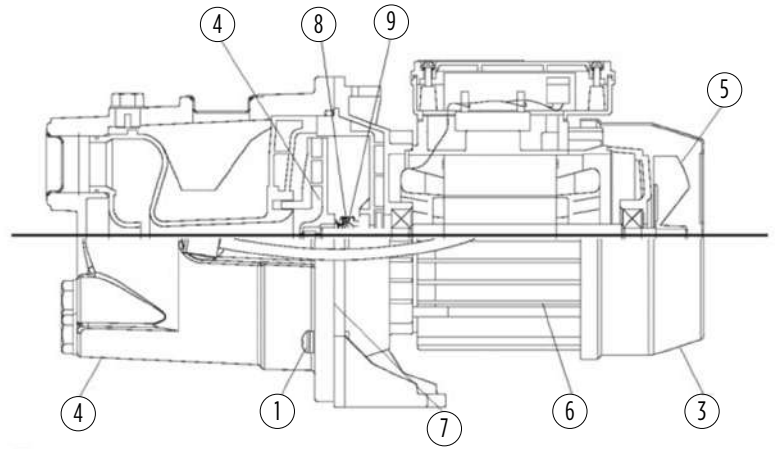

Figure 8

## TROUBLESHOOTING

PROBLEM	POSSIBLE CAUSE
Motor will not start	No power to pressure switch due to blown fuses, open switches or loose connections.
	Pump pressure switch not closed.
Pump fails to deliver water	Pump not completely primed.
	Suction lift is too great.
	Foot valve is either not submerged, buried in the mud or plugged.
	Restrictor valve is fully closed.
Pump loses prime	Air leaks in suction line.
	Well draws down too far.
	Faulty foot valve.
For well point installations where pump is losing pressure or unable to prime	Have an electrician install a low pressure cut-off switch to shut down the pump prior to critical failure.
	Install or adjust a restrictor valve to offset available capacity.
	Add a larger tank (20 gallon or larger) for additional capacity.

PROBLEM	POSSIBLE CAUSE
Pump delivers water but not at rated capacity	Leaks in suction or discharge line.
	Foot valve, suction line, impeller or nozzle are partially plugged.
	Suction lift is greater than recommended.
	Improper impeller rotation or low speed.
	Venturi or diffuser is plugged.
	Motor is wired for improper voltage.
	Low line voltage at motor.
	Filtration cartridge (if used) needs changing or is not installed properly.
Pump starts and stops too often	Faulty air volume control.
	Air leaks in tank above the water level.
	Incorrect setting on pressure switch.
	Tank is water logged or incorrectly charged.
	Foot valve leaks or is stuck open.

# REPLACEMENT PARTS

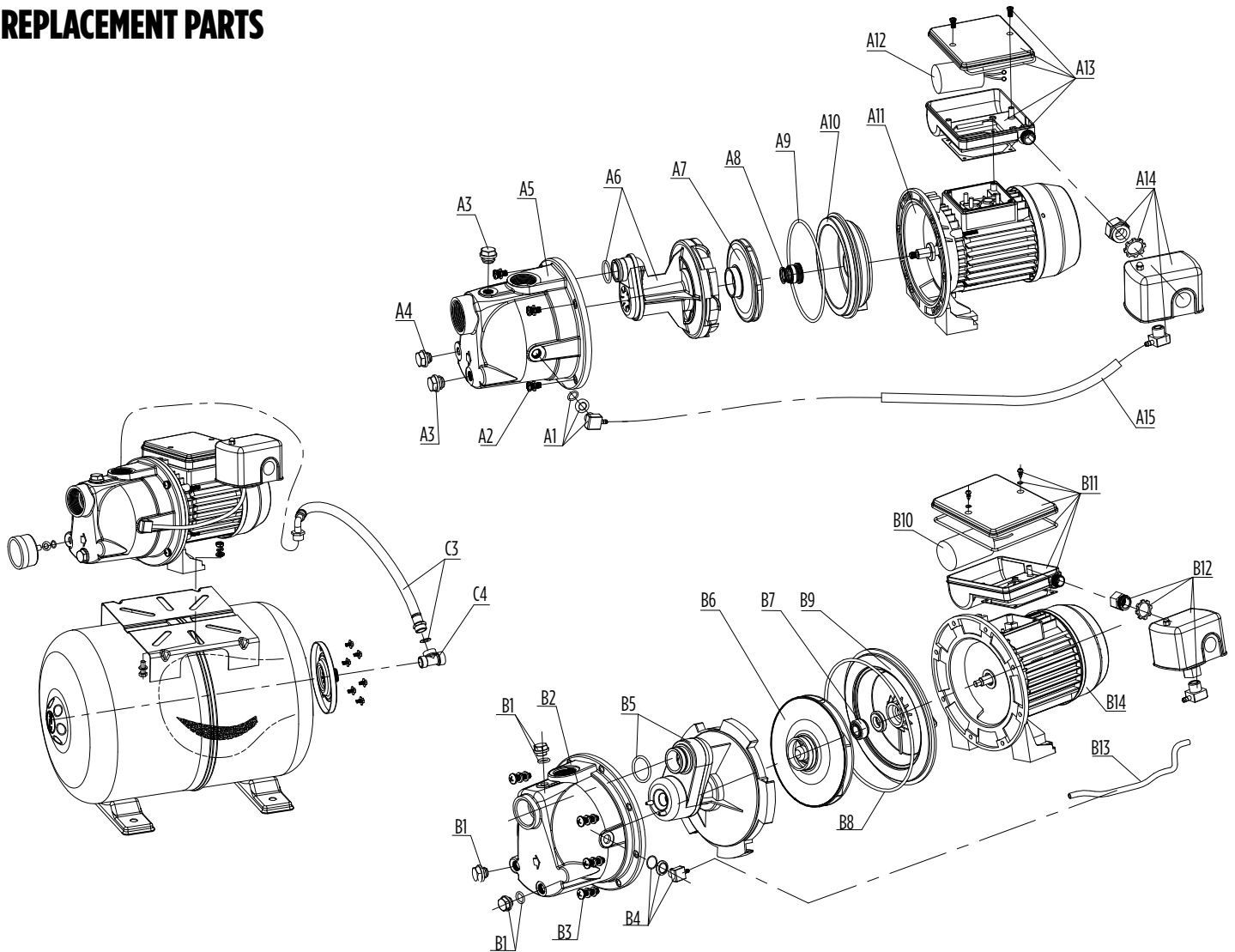

Contents	Item	Replacement Parts	Where Used
A5 & A10	305585001	Case/Seal Plate	RL-SWJ50 & RL-SWJ75
A2, A3, A4 & A9	305585002	Hardware Kit	RL-SWJ50 & RL-SWJ75
A6, A7 & A8	305585005	Overhaul Kit	RL-SWJ50
A6, A7 & A8	305585006	Overhaul Kit	RL-SWJ75
A7	305585008	Impeller Kit	RL-SWJ50
A7	305585009	Impeller Kit	RL-SWJ75
A8	305585011	Shaft Seal Kit	RL-SWJ50 & RL-SWJ75
A1, A14 & A15	305585012	Pressure Switch Kit	RL-SWJ50 & RL-SWJ75
B2 & B9	305585003	Case/Seal Plate	RL-SWJ100
B1, B3 & B8	305585004	Hardware Kit	RL-SWJ100
B5, B6 & B7	305585007	Overhaul Kit	RL-SWJ100
B6	305585010	Impeller Kit	RL-SWJ100
B7	305585011	Shaft Seal Kit	RL-SWJ100
B4, B12 & B13	305585012	Pressure Switch Kit	RL-SWJ100
C3, C4	305592001	Pump/Tank Hardware Kit	RL-SWJ50/RL6H



# LIMITED WARRANTY

For warranty consideration, the Red Lion® Brand (hereafter “the Brand”) warrants that the products specified in this warranty are free from defects in material or workmanship of the Brand. During the time periods and subject to the terms and conditions hereinafter set forth, the Brand will repair or replace to the original user or consumer any portion of this product which proves defective due to materials or workmanship of the Brand. At all times the Brand shall have and possess the sole right and option to determine whether to repair or replace defective equipment, parts, or components. The Brand has the option to inspect any product returned under warranty to confirm that the warranty applies before repair or replacement under warranty is approved. This warranty sets forth the Brand’s sole obligation and purchaser’s exclusive remedy for defective product. Return defective product to the place of purchase for warranty consideration.

**WARRANTY PERIOD - PRODUCTS:** 24 months from date of purchase by the user (No warranty on brushes, impeller or cam on models with brush-type motors and/or flex-vane impellers). In the absence of suitable proof of the purchase date, the effective period of this warranty will begin on the product’s date of manufacture.

**LABOR, ETC. COSTS:** The Brand shall IN NO EVENT be responsible or liable for the cost of field labor or other charges incurred by any customer in removing and/or affixing any product, part or component thereof.

**PRODUCT IMPROVEMENTS:** The Brand reserves the right to change or improve its products or any portions thereof without being obligated to provide such a change or improvement for units sold and/or shipped prior to such change or improvement.

**GENERAL TERMS AND CONDITIONS:** This warranty shall not apply to damage due to acts of God, normal wear and tear, normal maintenance services and the parts used in connection with such service, lightning or conditions beyond the control of the Brand, nor shall it apply to products which, in the sole judgment of the Brand, have been subject to negligence, abuse, accident, misapplication, tampering, alteration; nor due to improper installation, operation, maintenance or storage; nor to excess of recommended maximums as set forth in the instructions.

Warranty will be VOID if any of the following conditions are found:

1. Product is used for purposes other than those for which it was designed and manufactured
2. Product not installed in accordance with applicable codes, ordinances and good trade practices
3. Product connected to voltage other than indicated on nameplate
4. Pump used to circulate anything other than fresh water at approximately room temperature
5. Pump allowed to operate dry (fluid supply cut off)
6. Sealed motor housing opened or product dismantled by customer

**DISCLAIMER:** Any oral statements about the product made by the seller, the Brand, the representatives or any other parties, do not constitute warranties, shall not be relied upon by the user, and are not part of the contract for sale. Seller’s and the Brand’s only obligation, and buyer’s only remedy, shall be the replacement and/or repair by the Brand of the product as described above. NEITHER SELLER NOR THE BRAND SHALL BE LIABLE FOR ANY INJURY, LOSS OR DAMAGE, DIRECT, INCIDENTAL OR CONSEQUENTIAL (INCLUDING, BUT NOT LIMITED TO, INCIDENTAL OR CONSEQUENTIAL DAMAGES FOR LOST PROFITS, LOST SALES, INJURY TO PERSON OR PROPERTY, OR ANY OTHER INCIDENTAL OR CONSEQUENTIAL LOSS), ARISING OUT OF THE USE OR THE INABILITY TO USE THE PRODUCT, AND THE USER AGREES THAT NO OTHER REMEDY SHALL BE AVAILABLE TO IT. Before using, the user shall determine the suitability of the product for his intended use, and user assumes all risk and liability whatsoever in connection therewith. THE WARRANTY AND REMEDY DESCRIBED IN THIS LIMITED WARRANTY IS AN EXCLUSIVE WARRANTY AND REMEDY AND IS IN LIEU OF ANY OTHER WARRANTY OR REMEDY, EXPRESSED OR IMPLIED, WHICH OTHER WARRANTIES AND REMEDIES ARE HEREBY EXPRESSLY EXCLUDED, INCLUDING BUT NOT LIMITED TO ANY IMPLIED WARRANTY OF MERCHANTABILITY OR FITNESS FOR A PARTICULAR PURPOSE, TO THE EXTENT EITHER APPLIES TO A PRODUCT SHALL BE LIMITED IN DURATION TO THE PERIODS OF THE EXPRESSED WARRANTIES GIVEN ABOVE. Some states and countries do not allow the exclusion or limitations on how long an implied warranty lasts or the exclusion or limitation of incidental or consequential damages, so the above exclusion or limitations may not apply to you. This warranty gives you specific legal rights, and you may also have other rights which vary from state to state and country to country.

---

**For technical assistance, parts, or repair, please  
contact.... 1.888.956.0000 | [www.RedLionProducts.com](http://www.RedLionProducts.com)**

---