



SERVICE PARTS LIST

BULLETIN NO.
54-00-PXPC

SPECIFY CATALOG NO. AND SERIAL NO. WHEN ORDERING PARTS		REVISED BULLETIN	DATE
M18™ PEX Press/Crimper			Oct. 2019
CATALOG NO.	2674-20	SERIAL NUMBER	H14A
WIRING INSTRUCTION			

See page 2 for available Jaw Assemblies and lubrication / maintenance

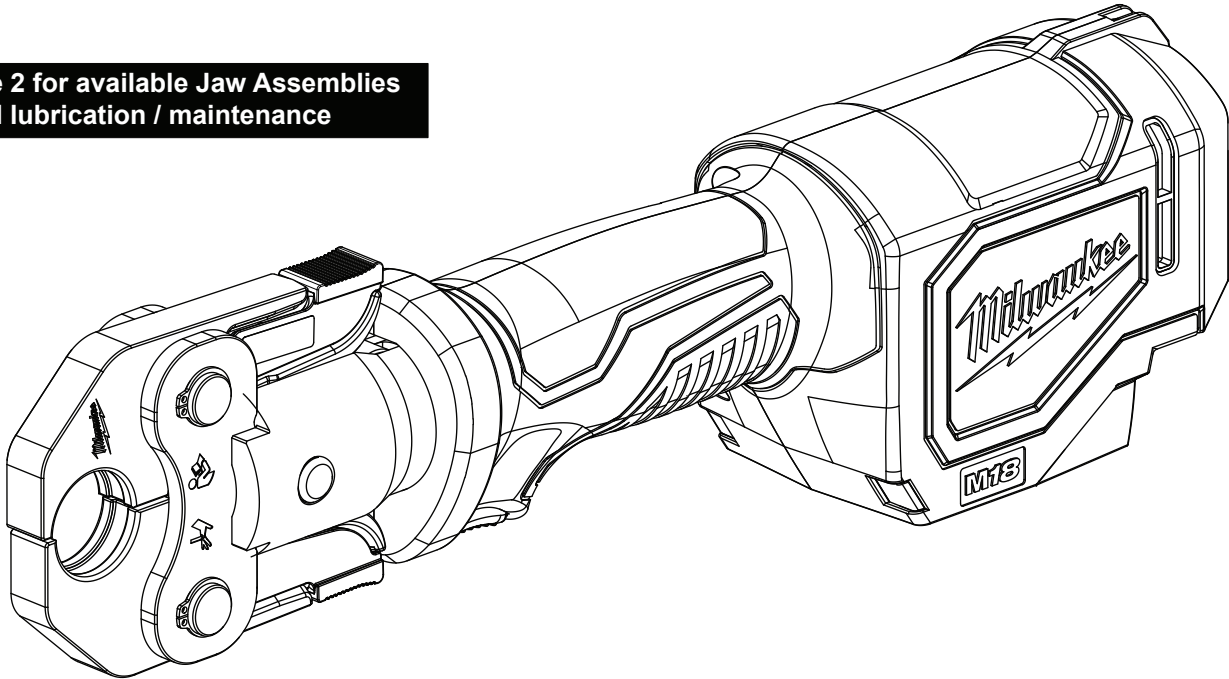

Due to the mechanical design and electronics in this tool, service can only be performed at this Milwaukee factory Repair Center:

**MILWAUKEE TOOL Central Repair
1401 Sycamore Avenue • Greenwood, MS 38930-7277**

Please send your tool directly to this location for service.

Or

Via e-Service at: www.milwaukeetool.com/e-service
questions, please call 1.800.SAWDUST (1.800.729.3878)

Or

Return it to a MILWAUKEE *factory* Service Center location, freight prepaid and insured.
A copy of the proof of purchase should be included with the return product.

If you have questions please contact Milwaukee Product Service at:

Product Technical Support via phone at: 262.783.8642

Or

Via email at: METProductSupport@milwaukeetool.com

Disassembly is not recommended and could void the warranty.

LUBRICATION:

Type S2 Grease (7 oz. tube), No. 49-08-5265

- A** Place a light, uniform coat of grease around the entire jaw transfer pin (1d).
- B** Lightly coat with grease the ID of pivot pin holes of both press jaws (1f & 1h). Be sure to place a light film of grease on the flange surfaces of both press jaws (1f & 1h) that contact the side plates (1c).
- C** Lightly coat with grease the ID of pivot pin holes of the jaw side plates (1c).
- D** Apply a light coat of grease to the clevis assembly (2a) as shown. Apply a light coat of grease to both rollers (2h) and the roller contact surfaces on the roller carrier (2j).

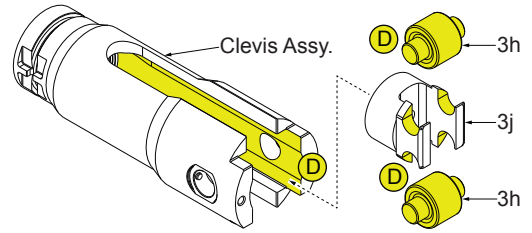

PEX PRESS JAW ASSEMBLIES for the 2674-22P

ITEM	PART NUMBER	DESCRIPTION OF PART	NO.REQ.
30	49-16-2634P	1" Pex Press Jaw Assembly	1
31	49-16-2633P	3/4" Pex Press Jaw Assembly	1
32	49-16-2632P	5/8" Pex Press Jaw Assembly	1
33	49-16-2631P	1/2" Pex Press Jaw Assembly	1
34	49-16-2630P	3/8" Pex Press Jaw Assembly	1
1A	44-86-0026	Retaining Ring	4
1B	-----	Pivot Pin	2
1C	-----	Jaw Side Plate	2
1D	-----	Jaw Transfer Pin	1
1E	-----	Leaf Spring	1
1F	-----	1" Pex Press Jaw	2
1F	-----	3/4" Pex Press Jaw	2
1F	-----	5/8" Pex Press Jaw	2
1F	-----	1/2" Pex Press Jaw	2
1F	-----	3/8" Pex Press Jaw	2
1G	-----	Jaw Clip With Orange For 1" Pex Press Jaw	2
1G	-----	Jaw Clip With Blue For 3/4" Pex Press Jaw	2
1G	-----	Jaw Clip With Red For 5/8" Pex Press Jaw	2
1G	-----	Jaw Clip With Yellow For 1/2" Pex Press Jaw	2
1G	-----	Jaw Clip With Green For 3/8" Pex Press Jaw	2

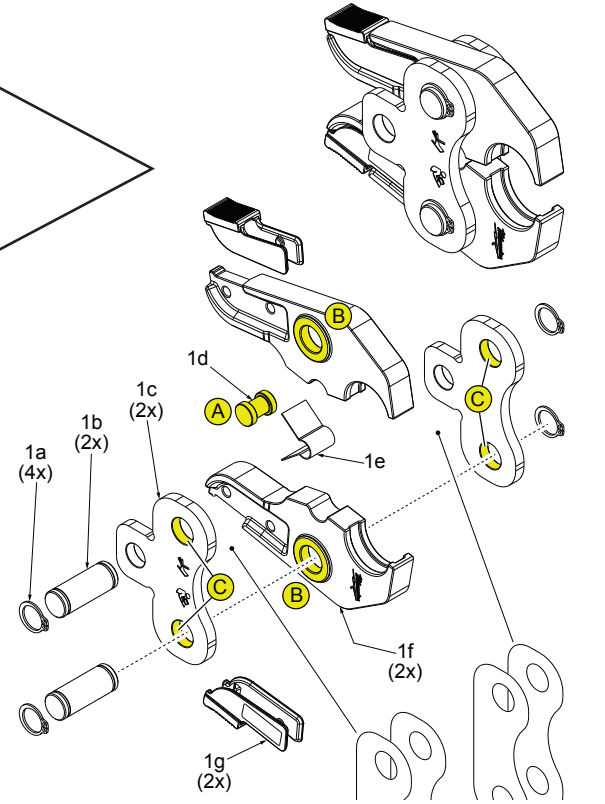

PEX CRIMP JAW ASSEMBLIES for the 2674-22C

ITEM	PART NUMBER	DESCRIPTION OF PART	NO.REQ.
35	49-16-2634C	1" Pex Crimp Jaw Assembly	1
36	49-16-2633C	3/4" Pex Crimp Jaw Assembly	1
37	49-16-2632C	5/8" Pex Crimp Jaw Assembly	1
38	49-16-2631C	1/2" Pex Crimp Jaw Assembly	1
39	49-16-2630C	3/8" Pex Crimp Jaw Assembly	1
1A	44-86-0026	Retaining Ring	4
1B	-----	Pivot Pin	2
1C	-----	Jaw Side Plate	2
1D	-----	Jaw Transfer Pin	1
1E	-----	Leaf Spring	1
1H	-----	1" Pex Crimp Jaw	2
1H	-----	3/4" Pex Crimp Jaw	2
1H	-----	5/8" Pex Crimp Jaw	2
1H	-----	1/2" Pex Crimp Jaw	2
1H	-----	3/8" Pex Crimp Jaw	2
1J	-----	Jaw Clip With Orange For 1" Pex Crimp Jaw	2
1J	-----	Jaw Clip With Blue For 3/4" Pex Crimp Jaw	2
1J	-----	Jaw Clip With Red For 5/8" Pex Crimp Jaw	2
1J	-----	Jaw Clip With Yellow For 1/2" Pex Crimp Jaw	2
1J	-----	Jaw Clip With Green For 3/8" Pex Crimp Jaw	2

