

**APPLICATION GUIDE**  
**FOR**  
**MULTIPLE**  
**GAS FIRED**  
**HOT WATER BOILER**  
**INSTALLATIONS**

***UP TO 4 UNITS***



Manufactured by:  
ECR International Inc.  
2201 Dwyer Avenue, Utica, NY 13501  
Tel. 800 325-5479  
[www.ecrinternational.com](http://www.ecrinternational.com)  
PN 240013666 REV. A [06/30/2022]

# Table of Contents

SAFETY INFORMATION .....	3-4
CODES AND STANDARDS .....	5
ENGINEERING AND DIMENSIONAL DATA.....	6
BOILER RATINGS & CAPACITIES .....	7
TYPICAL LAYOUTS FOR HOT WATER HEATING SYSTEMS.....	8-12
COMBUSTION AIR REQUIREMENTS .....	13
COMMON VENTING REQUIREMENTS.....	14
VENTILATION AND COMBUSTION .....	15
VENT INSTALLATION.....	16
REMOVAL OF BOILER FROM VENTING SYSTEM.....	17
GAS SERVICE .....	18
OPTIONAL CONTROLS AND WIRING.....	19
ARGO AMB CONTROLS .....	20-22

# SAFETY INFORMATION

**Become familiar with symbols identifying potential hazards.**

 This is the safety alert symbol. Symbol alerts you to potential personal injury hazards. Obey all safety messages following this symbol to avoid possible injury or death.

## **DANGER**

Indicates a hazardous situation which, if not avoided, WILL result in death or serious injury

## **WARNING**

Indicates a hazardous situation which, if not avoided, could result in death or serious injury.

## **CAUTION**

Indicates a hazardous situation which, if not avoided, could result in minor or moderate injury.

## **NOTICE**

Used to address practices not related to personal injury.

## **WARNING**

Fire, Explosion, Asphyxiation, Electrical shock hazard! Flooding will result in damages such as electrical problems, corrosion, inoperative parts, mold and other unforeseen issues which can occur over time. Any equipment determined by a professional as damaged by a flood, defined as excess of water or other liquid, shall be replaced. Failure to follow these directions will result in a Hazardous Situation.

FOR YOUR SAFETY READ BEFORE OPERATING

# DANGER



### Hot Water Can Scald!

Water heated to temperature for clothes washing, dish washing and other sanitizing needs can scald and cause permanent injury.

Children, elderly, and infirm or physically handicapped persons are more likely to be permanently injured by hot water. Never leave them unattended in bathtub or shower. Never allow small children to use a hot water tap or draw their own bath.

If anyone using hot water in the building fits the above description, or if state laws or local codes require certain water temperatures at hot water taps, you must take special precautions:

- Use lowest possible temperature setting.
- Install some type of tempering device, such as an automatic mixing valve, at hot water tap or water heater. Automatic mixing valve must be selected and installed according to manufacturer's recommendations and instructions.
- Water passing out of drain valves may be extremely hot. To avoid injury:  
Make sure all connections are tight.  
Direct water flow away from any person.

# SAFETY INFORMATION

## WARNING

Construction materials of appliance and products of combustion and fuel contain alumina, silica, heavy metals, carbon monoxide, nitrogen oxides, aldehydes and /or other toxic or harmful substances which can cause death or serious injury and which are known to the State of California to cause cancer, birth defects and other reproductive harm. Always use proper safety clothing, respirators and equipment when servicing or working nearby the appliance.

## WARNING

Combustion chamber insulation in this product contains ceramic fiber material. Ceramic fibers can be converted to cristobalite in very high temperature applications. The International Agency for Research on Cancer (IARC) has concluded, Crystalline silica inhaled in the form of quartz or cristobalite from occupational sources is carcinogenic to humans (Group1). Avoid breathing dust and contact with skin and eyes. Use NIOSH certified dust respirator (N95). This type of respirator is based on the OSHA requirements for cristobalite at the time this document was written. Other types of respirators may be needed depending on the job site conditions. Current NIOSH recommendations can be found on the NIOSH website <https://www.cdc.gov/niosh/topics/silica/>. approved respirators, manufacturers, and phone numbers are also listed on this website. Wear long-sleeved, loose fitting clothing, gloves, and eye protection. Apply enough water to the combustion chamber lining to prevent dust. Wash potentially contaminated clothes separately from other clothing. Rinse clothes washer thoroughly.

NIOSH stated First Aid. Eye: Irrigate immediately. Breathing: Fresh air.

## WARNING

This product contains Fibrous glass. Fibrous glass is a synthetic fiber made from tiny particles of glass. Fibrous glass has been classified as a possible human carcinogen. When disturbed as a result of servicing or repair, fibrous glass becomes airborne and, if inhaled, may be hazardous to your health. It can harm the eyes, skin, and the lungs. Airborne fibers from these materials have been listed by the State of California as a possible cause of cancer through inhalation. Adhere to the following precautions and procedures. Avoid breathing dust and contact with skin and eyes. Use NIOSH certified dust respirator (e.g., N95). Other types of respirators may be needed depending on the job site conditions. Current NIOSH recommendations can be found on the NIOSH website <https://www.cdc.gov/niosh/>. Approved respirators, manufacturers, and phone numbers are also listed on this website. Wear appropriate personal protective clothing to prevent skin contact, as well as gloves and eye protection. Wash skin daily at end of each work shift, and prior to eating, drinking, smoking, etc. Workers whose clothing may have been contaminated should change into uncontaminated clothing before leaving the work premises. Wash potentially contaminated clothes separately from other clothing. Rinse clothes washer thoroughly. Follow all Local, State and Federal guidelines for disposal.

NIOSH stated First Aid. Eye: Irrigate immediately. Breathing: Fresh air.

## CAUTION

### WHAT TO DO IF YOU SMELL GAS

- Do not try to light any appliance.
- Do not touch any electrical switch; do not use any phone in your building.
- Immediately call your gas supplier from a neighbor's phone. Follow gas supplier's instructions.
- If you cannot reach your gas supplier, call the fire department.

# Codes and Standards

## WARNING

Fire, explosion, asphyxiation and electrical shock hazard. Improper installation could result in death or serious injury. Read this instruction and individual boiler's Installation, Operation & Maintenance Manual and understand all requirements, including requirements of authority having jurisdiction, before beginning installation. Installation not complete until appliance operation verified per Installation, Operation & Maintenance Manual provided with each boiler.

## CODES AND STANDARDS

Installation shall be performed by a qualified service agency.

This instruction shall be used in conjunction with each unit's Installation, Operation and Maintenance Manual.

***Installation shall conform to requirements of authority having jurisdiction or in absence of such requirements:***

- United States
  - National Fuel Gas Code, ANSI Z223.1/NFPA 54.
  - National Electrical Code, NFPA 70.
- Canada
  - Natural Gas and Propane Installation Code, CAN/CSA B149.1 and B149.2
  - Canadian Electrical Code, Part I, Safety Standard for Electrical Installations, CSA C22.1

***Where required by authority having jurisdiction, installation shall conform to Standard for Controls and Safety Devices for Automatically Fired Boilers, ANSI/ASME CSD-1.***

Additional manual reset low water cutoff may be required.

Additional manual reset high temp limit may be required.

### ***Massachusetts:***

Boiler installation must conform to Commonwealth of Massachusetts code 248 CMR which includes but is not limited to installation by licensed plumber or gas fitter.

## WARNING

Keep boiler area clear and free from combustible materials, gasoline and other flammable vapors and liquids.

DO NOT obstruct air openings to the boiler room.

Modification, substitution or elimination of factory equipped, supplied or specified components may result in personal injury or loss of life.

TO THE OWNER - Installation and service of this boiler must be performed by a qualified installer.

TO THE INSTALLER - Leave all instructions with boiler for future reference.

When this product is installed in the Commonwealth of Massachusetts the installation must be performed by a Licensed Plumber or Licensed Gas Fitter.

# Engineering and Dimensional Data

## ⚠ WARNING

Fire, explosion, asphyxiation and electrical shock hazard. Improper installation could result in death or serious injury. Read this instruction and individual boiler's Installation, Operation & Maintenance Manual and understand all requirements, including requirements of authority having jurisdiction, before beginning installation. Installation not complete until appliance operation verified per Installation, Operation & Maintenance Manual provided with each boiler.

**Figure 1 - Dimensional Data**

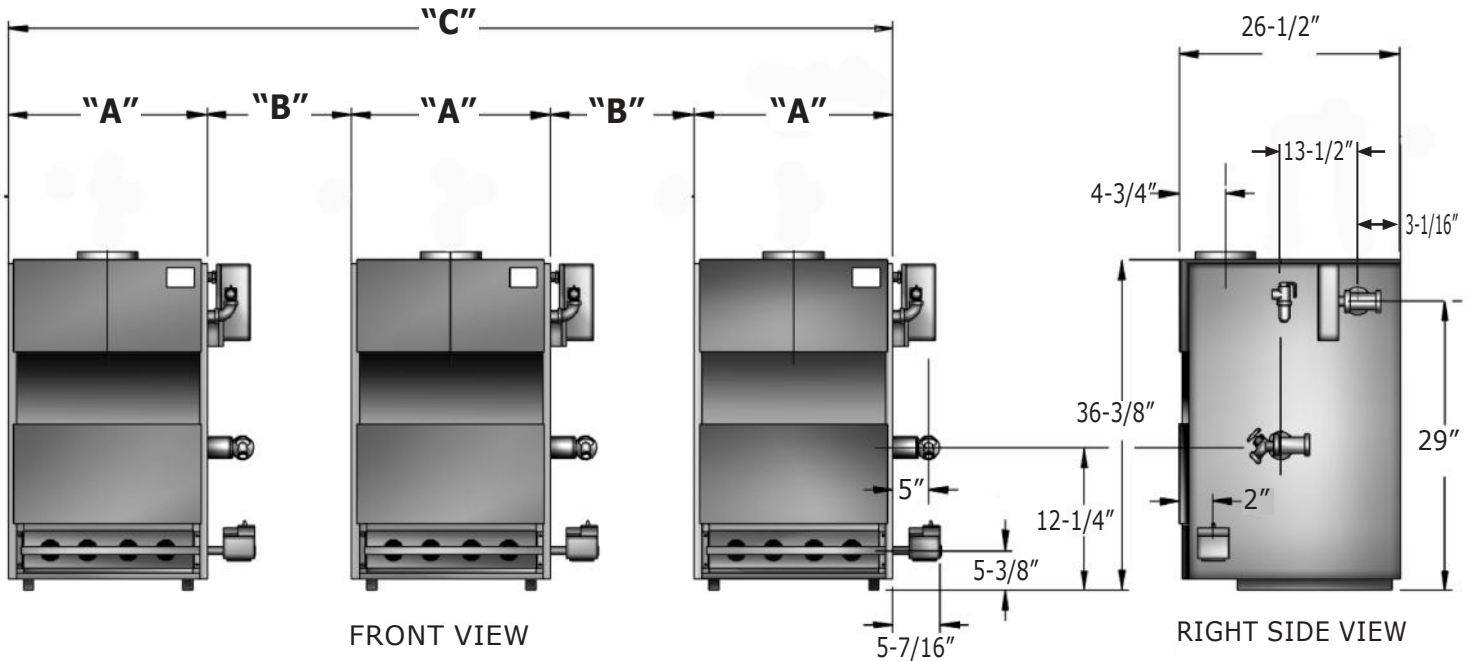

Table 1

MULTIPLE GAS FIRED HOT WATER BOILER ENGINEERING AND DIMENSIONAL DATA*						
Boiler Size	NUMBER OF BOILERS	SHIPPING WEIGHT (TOTAL)	WATER CONTENT (GALLONS) TOTAL**	DIMENSIONS IN INCHES		
				A	B***	C
8 Section	2	1105	20.2	27.5	10	75
9 Section	2	1232	23.6	30.75	10	81.5
8 Section	3	1656	30.3	27.5	10	112.5
9 Section	3	1848	34.8	30.75	10	122.25
8 Section	4	2210	40.4	27.5	10	150
9 Section	4	2464	47.2	30.75	10	163

\*Consult Individual Boiler Installation & Operation Manual for Additional Information

\*\* Exclusive of Field Installed External Piping

\*\*\* Requires 4' sensor wire (240007708) to relocate Hydrolevel 3200 control to front of boiler for access. If control is left in original position 24".

# Boiler Ratings & Capacities

Table 2

BOILER RATINGS							
Boiler Size	NUMBER OF BOILERS	TOTAL RATED INPUT	TOTAL RATED HEAT CAPACITY	TOTAL NET AHRI RATING	FLUE OUTLET DIAMETER, INCHES	COMMON VENT DIAMETER, INCHES	CHIMNEY DIAMETER AND HEIGHT
8 Section	2	525	442	384	7	12	12" x 20'
9 Section	2	598	504	438	7	12	12" x 20'
8 Section	3	787.5	663	576	7	14	14" x 20'
9 Section	3	897	756	657	7	14	14" x 20'
8 Section	4	1050	884	768	7	16	16" x 20'
9 Section	4	1196	1008	884	7	16	16" x 20'

**Figure 2 - Front View Common Venting**

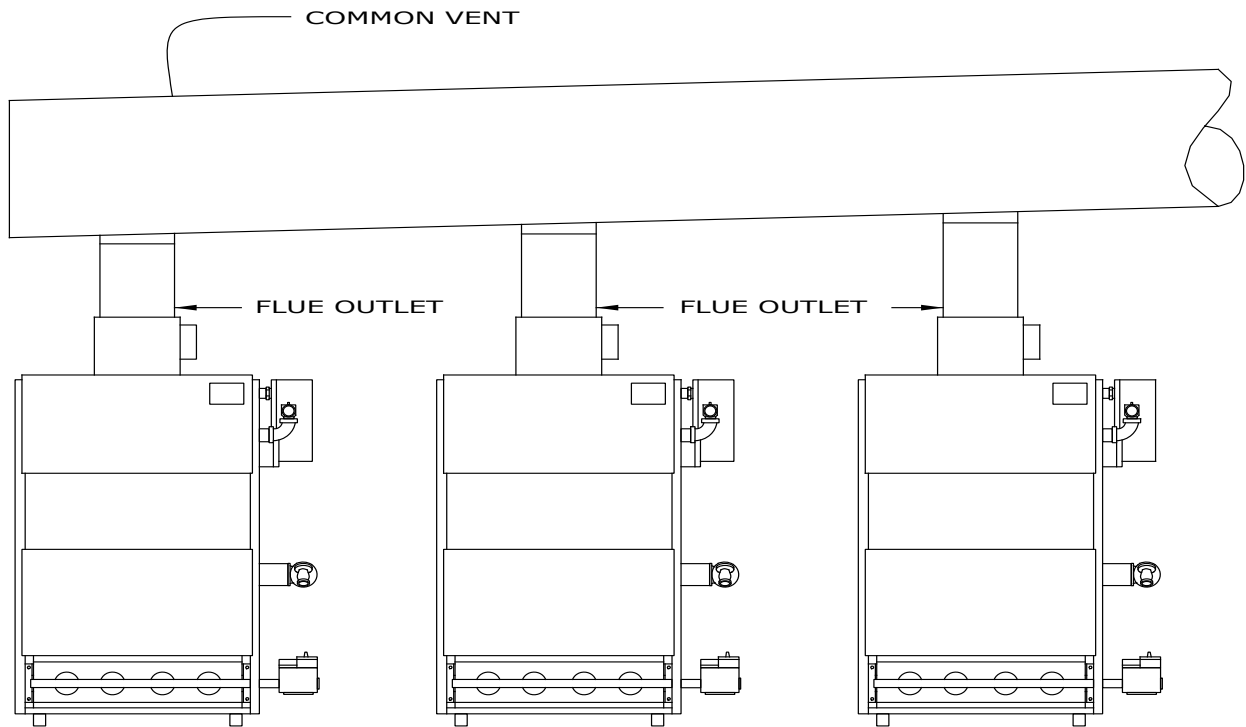

## FRONT VIEW

**NOTE: See Boiler Installation Operation and Maintenance Manual included in Literature for specific boiler installation requirements.**

# Typical Layouts for Hot Water Heating Systems

Figure 3 - Room Sizing - Parallel Reverse Return (3 Boilers shown)

(Supply & Return at Same Wall of Boiler Room)

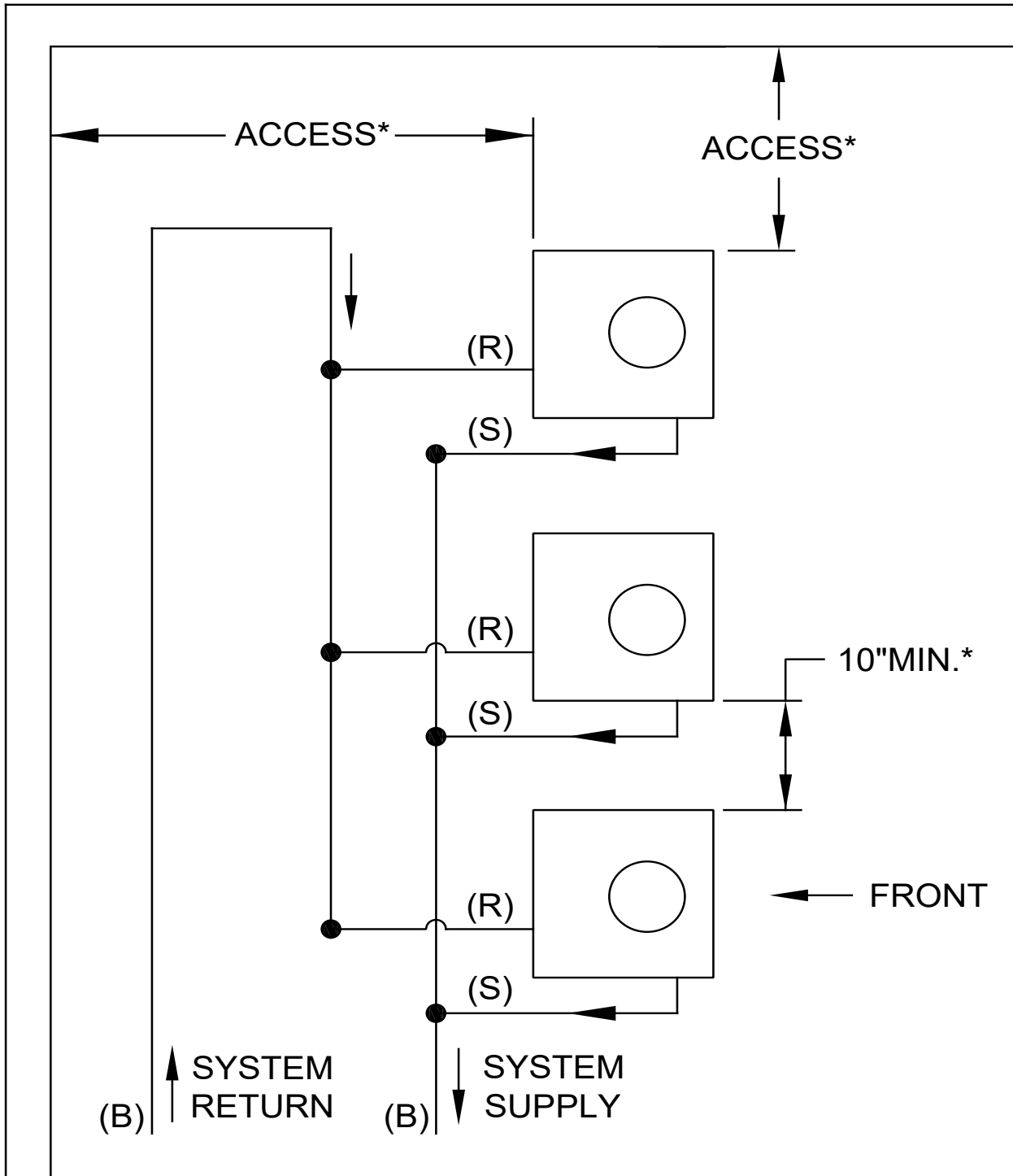

**LEGEND - PIPE SIZING**

(S),(R) - 1/4 NPT BOILER SUPPLY AND RETURN

(B) - HEADER SIZING - REFER TO TABLE 3

**Note:**

- Access \* is minimum 24" service clearance.
- Vent position, relief valve location, supply and return piping will vary depending on type of units.



# Typical Layouts for Hot Water Heating Systems

Figure 4 - Three (3) Unit Configuration Parallel Reverse Piping Room Sizing

(Supply & Return at Opposite Walls of Boiler Room)

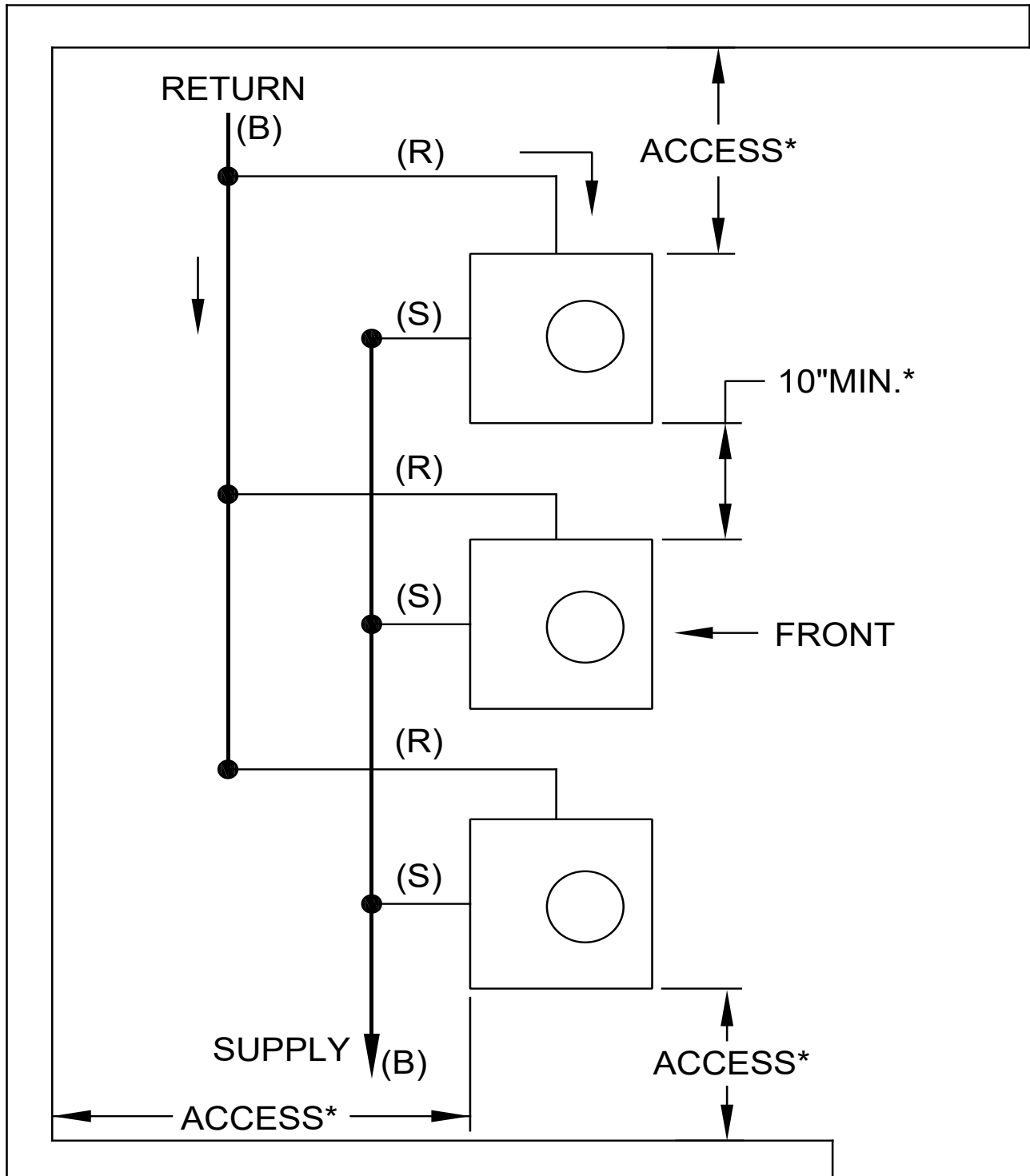

**LEGEND - PIPE SIZING**

(S), (R) - 1¼ NPT BOILER SUPPLY AND RETURN

(B) - HEADER - REFER TO TABLE 3

**Note:**

- Access \* is minimum 24" service clearance.
- Vent position, relief valve location, supply and return piping will vary depending on type of units.

# Typical Layouts for Hot Water Heating Systems

Figure 5 - Typical Layouts for Modular Gas Fired Systems - Up to 4 Boilers Parallel Piping

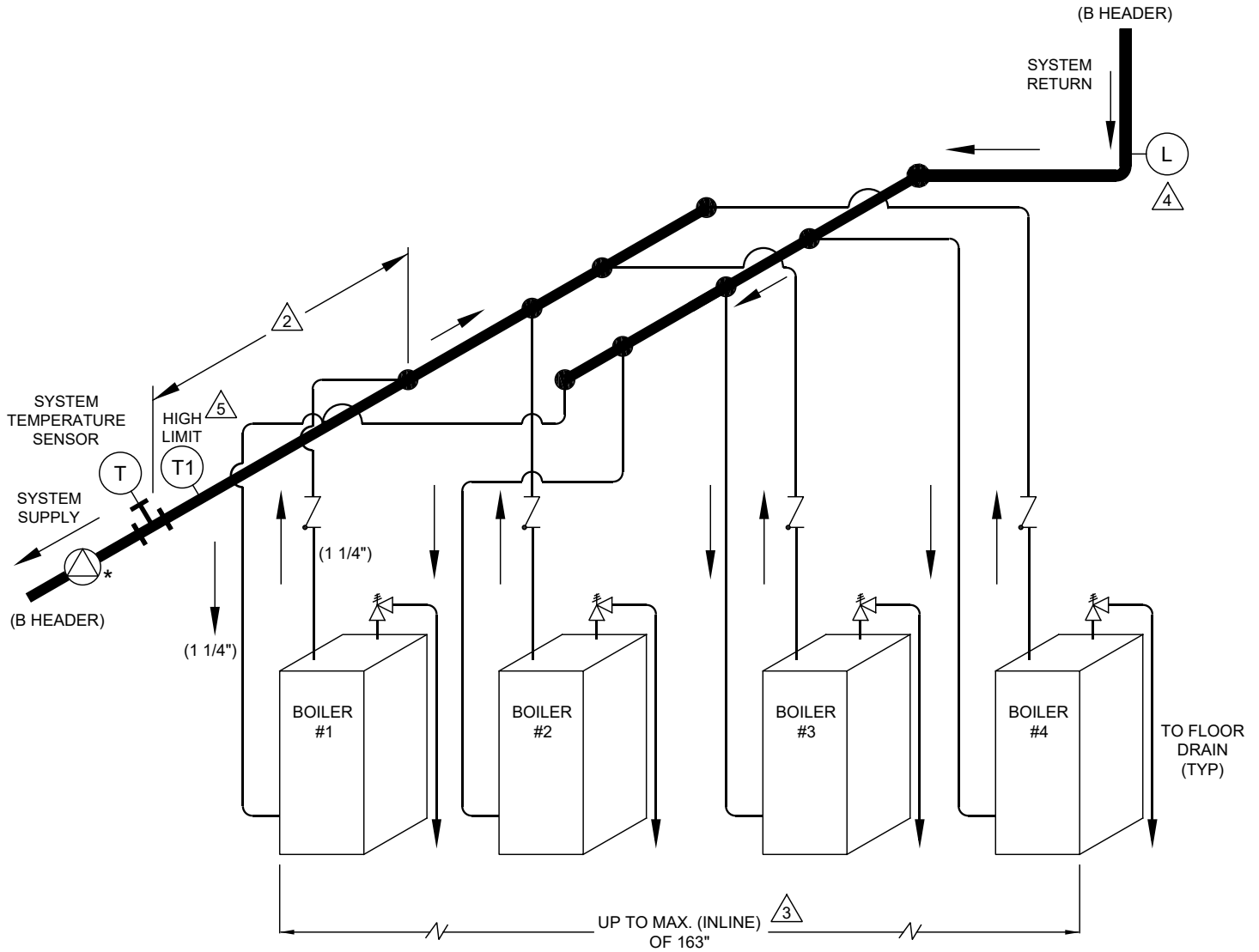

## UP TO 4 BOILERS

### LEGEND

- △ - Locate temperature sensor within 3 to 5 feet after supply header.
- △ - Maximum overall length is based on using (4) boilers having largest footprint and 24" minimum service clearance between units.
- △ - Low Water Cutoff Shall be mounted above the supply fitting of the boilers.
- △ - CSD-1 High Limit Shall be within 1' (1 foot) of nearest boiler.

### Note:

- Modules may be placed back to back to save space.
- Refer to figure 3 for header size.

\* For sizing system or boiler circulators, apply 10 GPM per 100,000 BTU (net) output.

LEGEND	
	CHECK VALVE
	CIRCULATOR
	PIPE CONNECTION
	TEMPERATURE SENSOR - SYSTEM
	PRESSURE RELIEF VALVE
FOR CSD-1	
	MANUAL RESET LOW WATER CUTOFF
	MANUAL RESET HI LIMIT
	SHALL SHUTOFF ALL BOILERS

# Typical Layouts for Hot Water Heating Systems

Figure 6 - Typical Layouts for Modular Gas Fired Systems - Up to 4 Boilers Reverse Parallel Piping

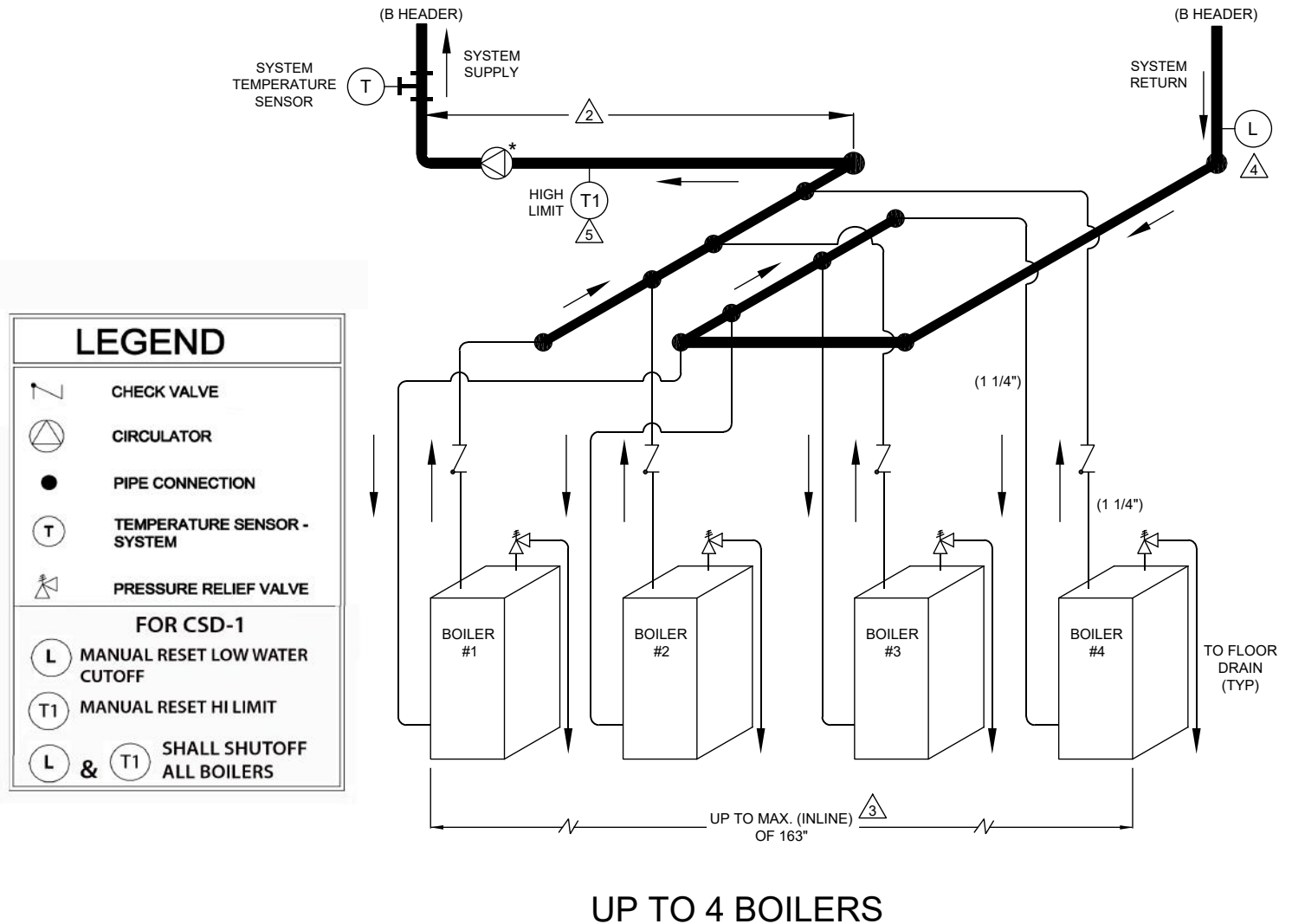

## LEGEND

- Locate temperature sensor within 3 to 5 feet after supply header.
- Maximum overall length is based on using (4) boilers having largest footprint and 24" minimum service clearance between units.
- Low Water Cutoff Shall be mounted above the supply fitting of the boilers.
- CSD-1 High Limit Shall be within 1' (1 foot) of nearest boiler.

## Note:

- Modules may be placed back to back to save space.
- Refer to figure 3 for header size.

\* For sizing system or boiler circulators, apply 10 GPM per 100,000 BTU (net) output.

# Typical Layouts for Hot Water Heating Systems

<b>Table 3 - HYDRONIC PIPE SIZING GUIDE</b>		
<b>COMBINED BOILER INPUT (MBTUH)</b>	<b>(Fig. 4 &amp; Fig. 6 ONLY)</b>	
	<b>MINIMUM PIPE SIZE (NPT)</b>	
	<b>(S), (R)</b>	<b>HEADER (B)</b>
<b>525</b>	1-1/4"	2"
<b>600</b>	1-1/4"	2-1/2"
<b>790</b>	1-1/4"	2-1/2"
<b>900</b>	1-1/4"	3"
<b>1,050</b>	1-1/4"	3"
<b>1,200</b>	1-1/4"	3"

# Combustion Air Requirements

## ⚠ WARNING

Asphyxiation hazard. Do not obstruct air openings to combustion area. Follow the chart below for adequate combustion air. Failure to comply could result in death or serious injury.

Refer to the individual boiler Installation, Operation and Maintenance Manual.

**Table 4 - COMBUSTION AIR REQUIREMENTS**

Boiler Size	NUMBER OF BOILERS	Total Rated Input	*UNCONFINED AREA		**CONFINED AREA OUTSIDE COMBUSTION	
			Outside combustion air 1 sq in/4000 BTU/hr (See Fig 2)	Inside combustion air 1 sq in/1000 BTU/hr (See Fig 1)	Vert. Ducts 1 Sq. In. /4000 Btuh/Hr	Horz. Ducts 1 Sq. In. /2000 Btuh/Hr
8 Section	2	525	150	600	150	300
9 Section	2	598	150	600	150	300
8 Section	3	787.5	200	800	200	400
9 Section	3	897	225	900	225	450
8 Section	4	1050	275	1100	275	550
9 Section	4	1196	300	1200	300	600

\* **Unconfined Area:** A space whose volume is not less than 50 cubic feet per 1000 Btu per hour of all appliances installed in that space (Cubic feet of space = height x width x length).

\*\* **Confined Area:** A space whose volume is less than 50 cubic feet per 1000 Btu per hour of all appliances installed in that space (Cubic feet of space = height x width x length).

**Figure 7 - Combustion Air Openings**

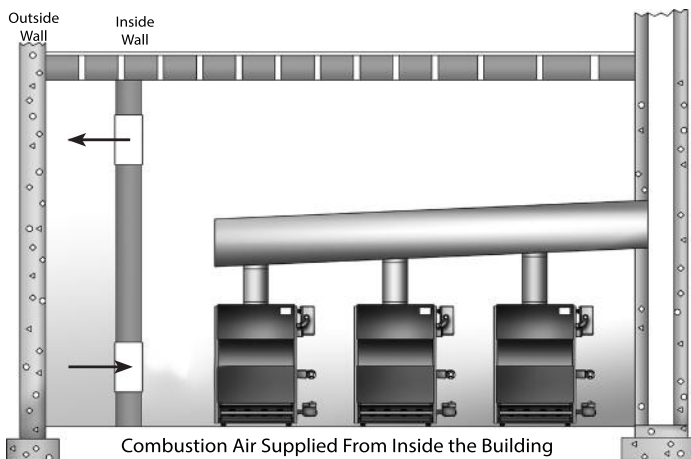

**Figure 8 - Combustion Air with Motorized Dampers**

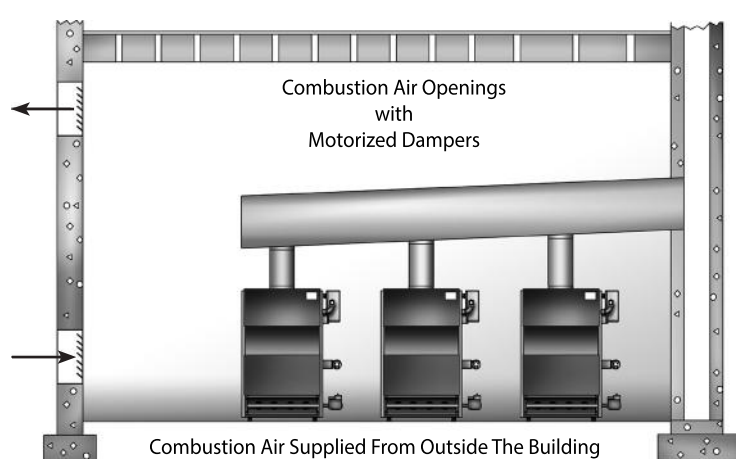

# Common Venting Requirements

**Table 5 - Common Vent Sizing Table for Multiple Boilers**

COMBINED INPUT (BTUH) x1000	Table 5 - COMMON VENT SIZING (INCHES) Vertical Vent Height (Ft)						
	6'	8'	10'	20'	30'	50'	100'
550	12	12	12	10	9	9	8
600	14	12	12	12	10	9	9
790	14	14	14	12	12	10	9
900	16	14	14	12	12	12	10
1,050	16	16	16	14	12	12	12
1,200	18	18	16	14	14	12	12

Table 5 based on TYPE-B Double-Wall vent using **un-assisted** Common Vent system. Reference is NFPA-54 / ANSI Z223.1 National Fuel Gas Code.

Consult NFPA-54 / ANSI Z223.1 National Fuel Gas Code. for "Mechanical Vent" Sizing and additional vent information.

Maximum Horizontal Vent Length shall not exceed allowable [Common Header Vent Size x 18"]. See Table 6. If longer Horizontal Vent Lengths are required – percentage reduction in capacity must be made to Table values. Consult NFPA-54 / ANSI Z223.1 National Fuel Gas Code.

**Table 6 - Maximum Horizontal Length of Common Vent**

COMMON VENT DIAMETER (INCHES)	MAXIMUM HORIZONTAL LENGTH FEET [INCHES]
8	12.0 [144"]
9	13.5 [162"]
10	15.0 [180"]
12	18.0 [216"]
14	21.0 [252"]
16	24.0 [288"]
18	27.0 [324"]

# Ventilation and Combustion

1. Ventilation of the boiler room must be adequate to provide sufficient air to properly support combustion per the latest revision of the National Fuel Gas Code, ANSI Z223.1/ NFPA-54.
2. When a boiler is located in an unconfined space in a building or conventional construction frame, masonry or metal building, infiltration normally is adequate to provide air for combustion and ventilation. However, if the equipment is located in a building of tight construction (See the National Fuel Gas Code, ANSI Z223.1) the boiler area should be considered as a confined space. If there is any doubt, install air supply provisions in accordance with the latest revision of the National Fuel Gas Code.
3. When a boiler is installed in an unconfined space, in a building of tight construction, air for combustion and ventilation must be obtained from outdoors or from spaces freely communicating with the outdoors. A permanent opening or openings having a total free area of not less than 1 square inch per 5,000 BTU per hour of total input rating of all appliances shall be provided. Ducts may be used to convey makeup air from the outdoors and shall have the same cross-sectional area of the openings to which they are connected.
4. When air for combustion and ventilation is from inside buildings, the confined space shall be provided with two permanent openings, one starting 12 inches from the top and one 12 inches from the bottom of the enclosed space. Each opening shall have a minimum free area of 1 square inch per one thousand (1000) BTU per hour of the total input rating of all appliances in the enclosed space, but must not be less than one hundred (100) square inches. These openings must freely communicate directly with other spaces of sufficient volume so that the combined volume of all spaces meets the criteria for an unconfined space. **See Figure #7.**
5. When the boiler is installed in a confined space and all air is provided from the outdoors the confined space shall be provided with one or two permanent openings according to methods A or B. When ducts are used, they shall be of the same cross sectional area as the free area of the area of the openings to which they connect. The minimum dimension of rectangular air ducts shall be not less than 3 x 3 inches or 9 square inches.
  - A. When installing two openings, one must commence within 12 inches from the top and the other within 12 inches from the bottom of the enclosure. The openings shall communicate directly, or by ducts, with the outdoors or spaces (crawl or attic) that freely communicate with the outdoors. One of the following methods must be used to provide adequate air for ventilation and combustion.
    - i. When directly communicating with the outdoors, each opening shall have a minimum free area of 1 square inch per 4,000 BTU per hour of total input rating of all equipment in the enclosure. **See Figure #8.**
    - ii. When communicating with the outdoors by means of vertical ducts, each opening shall have a minimum free area 1 square inch per 4,000 BTU per hour of total input rating of all appliances in the enclosed space.
    - iii. If horizontal ducts are used, each opening and duct shall have a minimum free area 1 square inch per 2,000 BTU per hour of total input rating of all appliances in the enclosed space.
  - B. One permanent opening, commencing within 12 inches of the top of the enclosure, shall be permitted where the equipment has clearances of at least 1 inch from the sides, 1 inch from the back, and 6 inches from the front of the boiler. The opening shall directly communicate with the outdoors or shall communicate through a vertical or horizontal duct to the outdoors or spaces (crawl or attic) that freely communicate with the outdoors. The openings must have a minimum free area of 1 square inch per 3000 Btu per hour of the total input rating of all equipment located in the enclosure. The free area must be no less than the sum of the areas of all vent connectors in the confined space.
6. In calculating free area using louvers, grilles or screens for the 6. above, consideration shall be given to their blocking effect. Screens used shall not be smaller than ¼ inch mesh. If the free area through a design of louver or grill is known, it should be used in calculating the size opening required to provide the free area specified. If the design and free area is not known, it may be assumed that wood louvers will have 20-25% free area and metal louvers and grilles will have 60-75% free area. Louvers and grilles should be fixed in the open position or interlocked with the boiler so they are opened automatically during the boiler operation.

# Vent Installation

## ⚠ WARNING

Asphyxiation hazard. This boiler is to be vented by natural draft and shall not be connected to the mechanical draft system operating under positive pressure. Failure to comply could result in death or serious injury.

1. The vent pipe must slope upward from the boiler not less than 1 inch.  $\frac{1}{4}$  inch for every 1 foot to the vent terminal.
2. Horizontal portions of the venting system shall be supported rigidly every 5 feet and at the elbows. No portion of the vent pipe should have any dips or sags.
3. This boiler series is classified as a Category 1 and the vent installation shall be in accordance with the National Fuel Gas Code noted above or applicable provisions of the local building codes.
4. Inspect chimney to make certain it is constructed according to NFPA 211. The vent or vent collector shall be Type B or metal pipe having resistance to heat and corrosion not less than that of galvanized sheet steel or aluminum not less than 0.016 inch thick (No. 28 Ga).
5. Connect flue pipe from draft hood to chimney. Bolt or screw joints together to avoid sags. Flue pipe should not extend beyond inside wall of chimney. Do not install manual damper in flue pipe or reduce size of flue outlet except as provided by the latest revision of ANSI Z223.1. Protect combustible ceiling and walls near flue pipe with fireproof insulation. Where two or more appliances vent into a common flue, the area of the common flue must be at least equal to the area of the largest flue plus 50 percent of the area of each additional flue.

## VENT DAMPER INSTALLATION

**NOTE: Refer to Figures 9 & 10 for steps 1-7**

1. Place Vent Damper on or as close to vent outlet of boiler as possible. See Figure #9.
2. Ensure each boiler is serviced by its' own vent damper. See Figure #10.
3. Ensure vent damper of each boiler will not interfere with safe venting of other boilers. See Figure #10.
4. Clearance of not less than 6 inches between vent damper and combustible material shall be maintained. Additional clearance should be allowed to service of the vent damper.
5. Refer to vent damper section of boiler IOM.
6. Vent damper shall be in the open position when appliance main burners are operating.
7. The vent damper position indicator must be in a visible location following installation.

Figure 9

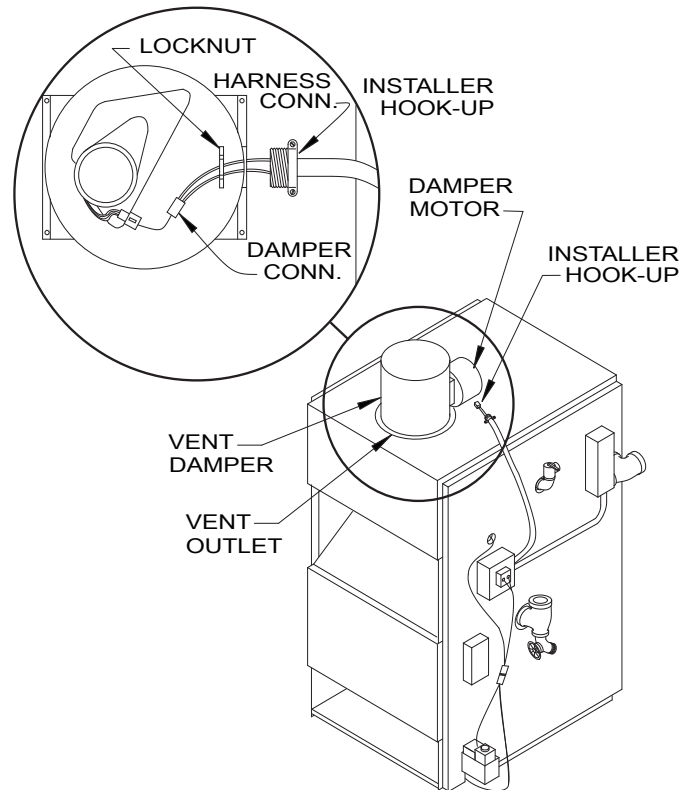
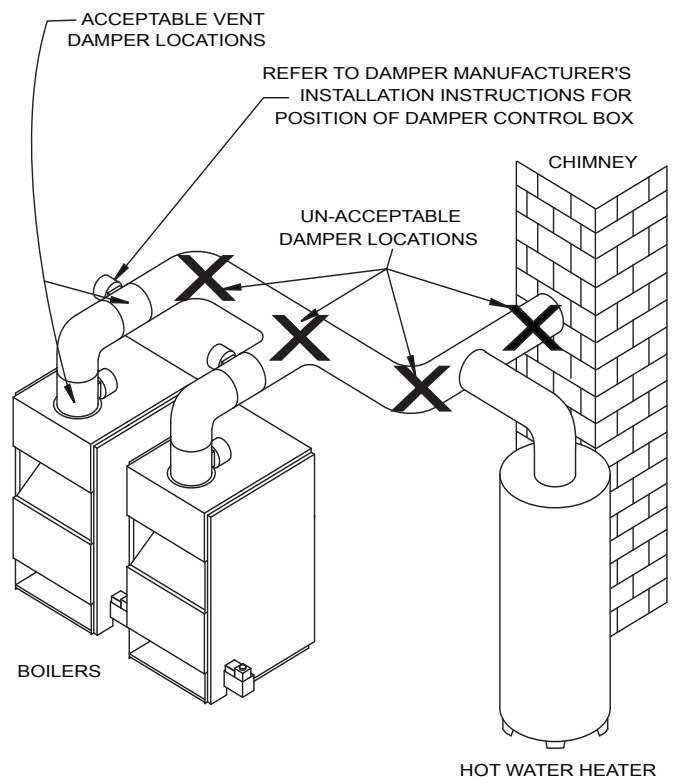

Figure 10





# Removal of Boiler from Venting System

When an existing boiler is removed from a common venting system, the common venting system is likely to be too large for the proper venting of the appliances remained connected to it. If this situation occurs, the following test procedure must be followed:

## REMOVAL OF BOILER FROM VENTING SYSTEM

At the time of removal of an existing boiler, the following steps shall be followed with each appliance remaining connected to the common venting system placed in operation, while the other appliances remaining connected to the common venting system are not in operation.

1. Seal an unused opening in the common venting system.
2. Visually inspect the venting system for proper size and horizontal pitch and determine there is no blockage or restriction, leakage, corrosion and other deficiencies which could cause an unsafe condition.
3. Insofar as is practical, close all building doors and windows and all doors between the space in which the appliances remaining connected to the common venting system are located and other spaces of the building. Turn on clothes dryers and any other appliance not connected to the common venting system. Turn on any exhaust fans, such as range hoods and bathroom exhausts, so they operate at maximum speed. Do not operate a summer exhaust fan. Close fireplace dampers.
4. Place in operation the appliance being inspected. Follow the lighting instructions. Adjust thermostat so appliance will operate continuously.
5. Test for spillage at the draft hood relief opening after 5 minutes of main burner operation. Use the flame of a match or candle, or smoke from a cigarette, cigar or pipe.
6. After it has been determined that each appliance remaining connected to a common venting system properly vents when tested as outlined above, return doors, windows, exhaust fans, fireplace dampers and any other gas burning appliances to their previous condition of use.
7. Any improper operation of the common venting system should be corrected so the installation conforms with the latest revision of the National Fuel Gas Code, ANSI Z223.1. When re-sizing any portion of the common venting system, the common venting system should be re-sized to approach the minimum size as determined using the appropriate tables in the latest revision of the National Fuel Gas Code, ANSI Z223.

# Gas Service

See individual unit's Installation, Operation & Maintenance Manual for piping requirements.

Table 7 - Pipe Sizes In Inches For Natural Gas Main										
Boiler Size	NUMBER OF BOILERS	TOTAL RATED INPUT	RUN LENGTH IN FEET							
			20	30	40	50	60	80	100	125
8 Section	2	525	1.25"	1.25"	1.50"	1.50"	2.00"	2.00"	2.00"	2.00"
9 Section	2	598	1.25"	1.25"	1.50"	1.50"	2.00"	2.00"	2.00"	2.00"
8 Section	3	787.5	1.25"	1.50"	1.50"	2.00"	2.00"	2.00"	2.00"	2.00"
9 Section	3	897	1.50"	2.00"	2.00"	2.00"	2.00"	2.00"	2.50"	2.50"
8 Section	4	1050	1.50"	2.00"	2.00"	2.00"	2.00"	2.50"	2.50"	2.50"
9 Section	4	1196	2.00"	2.00"	2.00"	2.00"	2.50"	2.50"	2.50"	2.50"

Table based on pressure drop of 0.3" water column at less than 2 psi inlet gas pressure.

Based on Natural gas and schedule 40 piping.

For other conditions and LP gas piping consult NFPA 54.

**Figure 11 - Gas Piping - Modular Boilers**

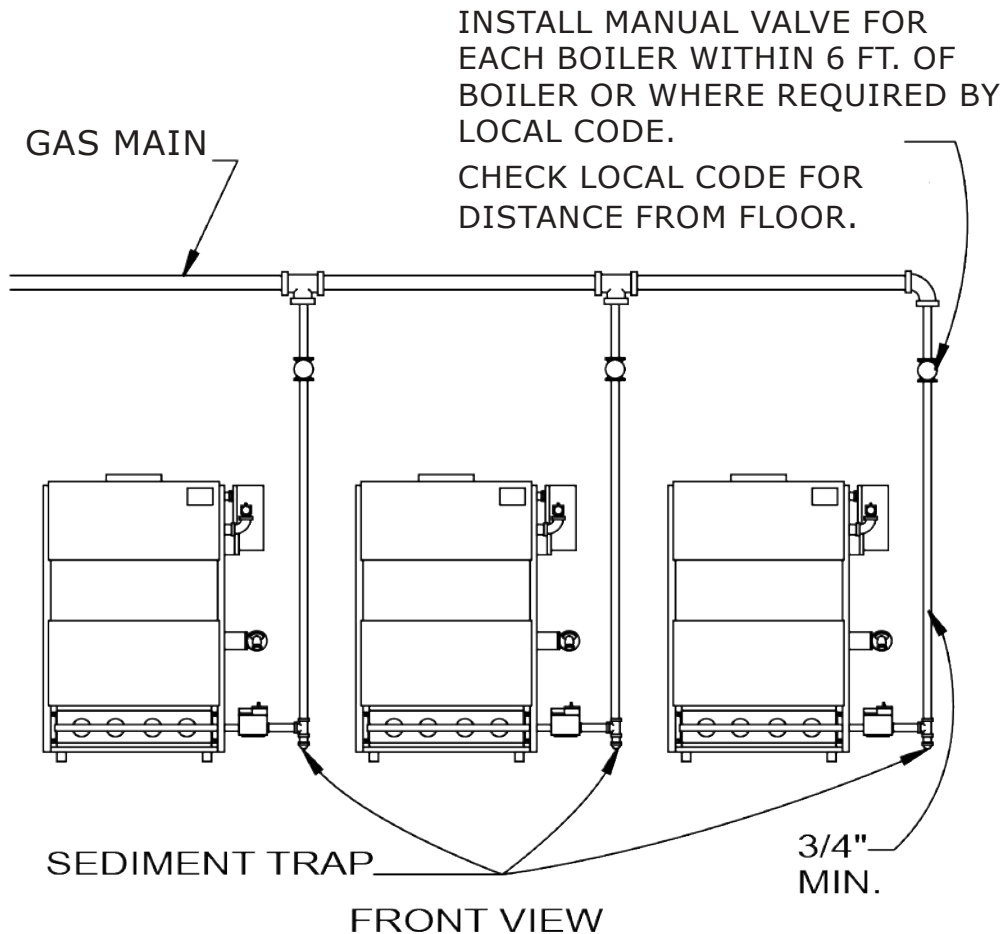

# Optional Controls and Wiring

Following descriptions outline control options for modular systems.

## Argo AMB4B Multiple Boiler CONTROL

- AMB4B multiple boiler sequencers are capable of sequentially step firing up to 4 (AMB4A) heating boilers.
- The number of boilers fired is adjusted by the AMB control depending on system heating load and outdoor temperature.
- AMB control will adjust control point of system water temperature based on the temperature that the outdoor air sensor is reading.
- Number of hours on each boiler in the system is recorded and each day the AMB control will choose the boiler with the fewest hours to be the lead boiler for the day to attempt to run each boiler equally and extend boiler life.
- Setpoint, reset ratio, rotation and many other features are easily programmed in the field through the four button user interface.

## Operation

- When used in a continuous application the AMB will regulate the water temperature in the system through the use of the water sensor and it will always keep the water warm.
- AMB will monitor the water temperature until the temperature drops the number of degrees below the control point that the temperature differential feature is set to.
- The control will then bring on the lead boiler. The AMB will monitor the boiler temperature and if it has not reached the control point it will bring on the next boiler.
- Boilers will be phased on or off based on how close the water temperature is to the control point.
- If at any point the water temperature is 10°F above the control point, all boilers will turn off.

# Argo AMB Controls

Figure 12 - Wiring ARGO AMB - 4 Control to Multiple Boilers

Model Number	Domestic / International	Transformer Voltage
ARGO AMB-4	Domestic	120V/60Hz/40Va

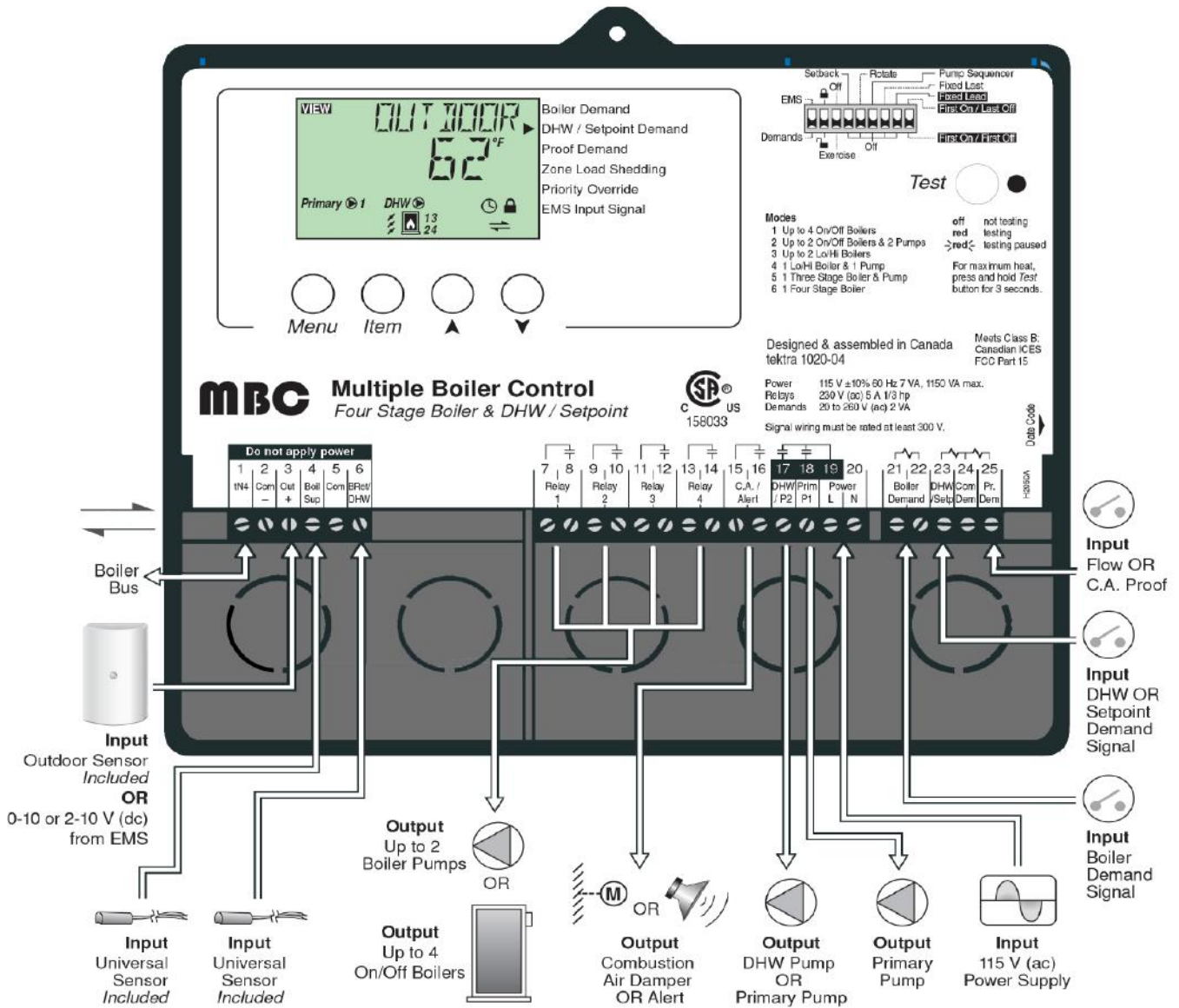

Consult ARGO AMB installation manual for additional information.

# Argo AMB Controls

## AMB-4 Multiple Boiler Control (MBC) Application

1. **Sequence of Operation** – The control will drive the boilers to a target water temperature based on demand from:
  - A. Boiler Demand: A target water temperature is calculated based on a programmable heating curve.
    - i. The control can receive boiler demand either from 20 – 260V (ac) to terminals 21 and 22, or from an Energy Management System (EMS) by applying 0-10 or 2-10 V (dc) signal to terminals 2 & 3 when the DIP switch is set to EMS.
    - ii. Supply water target temperature is determined by a signal from building energy management system or outdoor reset.
    - iii. Heating curve may also adjust supply temperature based on building heat distribution (radiant floor, fan-coil, baseboard, etc.)
    - iv. It is recommended minimum supply temperature be such that corresponding return water temperature be at least 120 degrees F to prevent condensation in the boiler. Generally, this will require minimum supply water temperature of at least 140°F, or provide boilers with bypass as describe in boiler instructions.
    - v. Optional warm weather shutdown is available.
    - vi. The Hydrolevel control will not allow a supply temperature setting above 220° F.
    - vii. The MBC may operate up to four on/off boilers as a heat source. For proper operation of the boilers, the MBC must be the only control that determines when a boiler is to fire.  
*\*Important note:* The boiler control (Hydrolevel 3200) must remain in the burner circuit and act as a secondary upper limit on the boiler temperature. The Hydrolevel 3200 temperature setting must be adjusted above the MBC's boiler maximum setting to prevent short cycling of the burner.
    - viii. The MBC includes a rotate feature to change the firing order of the boilers. Various boiler sequencing options are available as described in the MBC instructions.
  - B. Domestic Hot Water: DHW demand may be driven by either an aquastat or DHW sensor.
    - i. When DHW demand is present, the control will specify the higher of either the DHW supply temperature or calculated CH supply temperature.
    - ii. DHW is provided by providing power to the DHW loop circulator.
    - iii. DHW demand may be assigned priority, or not. If DHW is given priority, and the total demand exceeds boiler capacity, the CH circulator will shut off. DHW priority period time may be set to automatically calculate and vary depending upon outdoor temperature at the time.
    - iv. DHW loop may be piped in parallel with primary circuit.
  - C. Setpoint Operation: Not available if DHW mode is in use.
    - i. The control will select the higher of the setpoint temperature or current target water temperature.
    - ii. Setpoint demand is generated from a 20 to 260V signal applied across the appropriate terminals.
    - iii. Operating mode can be varied depending upon piping arrangement.

# Argo AMB Controls

2. **Energy Management System** - The control can accept an external DC signal from an Energy Management System (EMS) in place of the outdoor sensor. The control converts the DC signal into the appropriate boiler target temperature between 50°F (10°C) and 210°F (99°C) based on the EMS Input Signal and Offset settings. To use the external input signal, the EMS / Demands DIP switch must be set to EMS. Also, the supply temperature on the boiler controls must be set above 210°F (99°C).
  - A. Input signal: The control can accept either a 0 - 10 V (dc) signal or a 2 - 10 V (dc) signal. The External Input Signal setting must be set to the proper setting based on the signal that is being sent to the control.
  - B. DHW/Setpoint operation with external signal: Whenever an external signal is used, the control can still provide all DHW OR Setpoint functions.
3. **Pump Operation** – The control includes two primary pump outputs with capability for sequencing. Primary pump sequencing is activated through a DIP switch. Only primary pump 1 is operated when pump sequencing is turned off, while primary pumps 1 and 2 are operated in stand-by mode when pump sequencing is turned on.

The running times of the primary pumps are logged in the view menu. To reset these values back to zero, press and hold the up and down button while viewing this item.

Note: once primary pump sequencing is selected, DHW operation is not available. Setpoint operation, however, is available if primary pump sequencing is selected.

The primary pumps will operate when the control receives an appropriate demand:

External Boiler Demand

DHW Demand and the control is set to DHW Mode 3, 4, or 6.

Setpoint Demand and the control is set to Setpoint Mode 3 or 4.

The primary pumps also operate when the control is completing a DHW Purge.

**Flow Proof** - The control includes a flow proof demand in order to prove flow once a primary pump has turned on. In order for boiler operation to commence, the proof demand must be present. A flow proof signal is required at all times during pump operation. A flow proof is generated by applying a voltage between 20 and 260 V (ac) across the Flow Proof terminals (30 and 31). Once voltage is applied, the Proof Demand indicator is turned on in the LCD.

Once a pump contact is turned on, a flow proof signal must be present before the flow proof delay has expired.

The flow proof demand is selected by setting the Proof Demand item in the Adjust menu to F P (flow proof).

A flow proof demand can come from a flow switch, pressure differential switch, current sensing or power sensing device.

The control only operates one primary pump at a time. A flow proof device can be used to detect when stand-by pump operation is required.





2201 Dwyer Avenue, Utica, NY 13501  
Tel. 800 325 5479  
[www.ecrinternational.com](http://www.ecrinternational.com)

All specifications subject to change without notice.  
©2022 ECR International, Inc.