



COMMERCIAL HEAVY-DUTY PLASTIC TOILET SEAT

MODEL #

COLOR #

10SSCTFR

DESCRIPTION :

Open front less cover, elongated, heavy-duty, injection molded solid plastic toilet seat. Features four molded-in bumpers, self-sustaining check hinges with non-corrosive 300 Series stainless steel posts and pintles and STA-TITE® Commercial Fastening System™. Seat contains DuraGuard® Antimicrobial Built-In Seat Protection™ and FirePro™ a fire retardant material to meet UL-94V0 flammability rating. This seat complies with American National Standard Z124.5 Toilet (Water Closet) Seats as a class Commercial Heavy Duty.

SPECIFICATIONS :

Size:	Elongated
Material:	Plastic
Style:	Open Front less Cover
Bumpers:	Four
Hinges:	Plastic Self-Sustaining with 300 Series Stainless Steel Posts and Pintles
Fastening System:	STA-TITE® Commercial Fastening System™

FEATURES :

- STA-TITE® Commercial Fastening System™
- DuraGuard® Antimicrobial Built-In Seat Protection™
- FirePro™ Fire Retardant Material
- Non-Corrosive 300 Series Stainless Steel Posts and Pintles

DIMENSIONS :

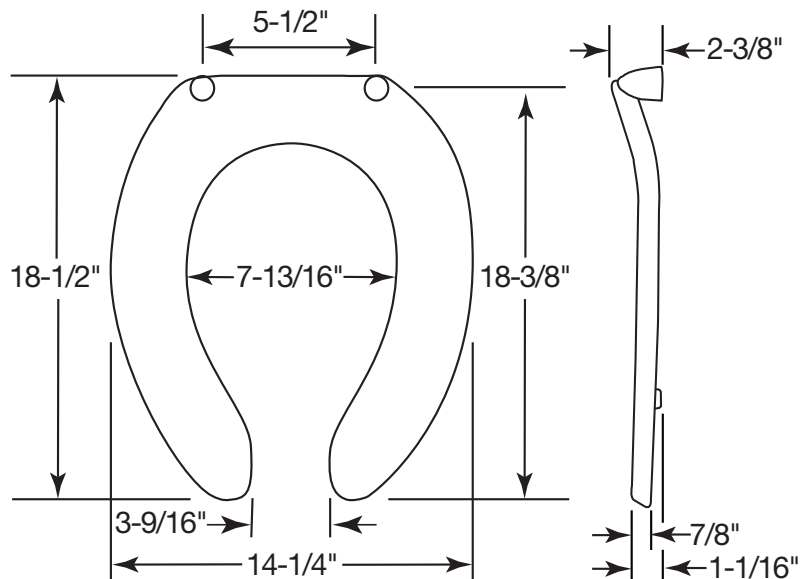

PLASTIC HINGES WITH STAINLESS STEEL POSTS AND PINTLES

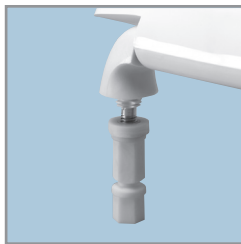

STA-TITE® COMMERCIAL FASTENING SYSTEM™



Olsonite, Sheboygan Falls, WI 53085
www.ToiletSeats.com

Phone: 920-467-4621 | 800-558-7651 Fax: 920-467-8573

©2013 0B7012324 REVA