

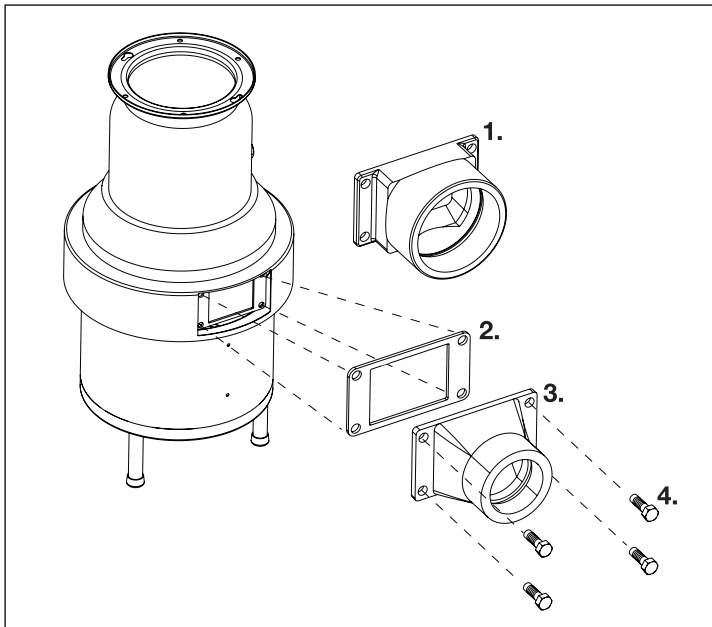

# WASTE FLANGE OUTLET

## FLANGE CREATES SALES OPPORTUNITIES:

- This flange reduces a three-inch waste line down to a two-inch line.
- Sell larger units to customers with two-inch waste lines.
- Replace competitive units with larger InSinkErator® units to customers with two-inch waste lines.
- InSinkErator still recommends that you use a three-inch waste line whenever possible for larger units.
- To order, specify Part #13847.



## INSTALLATION INSTRUCTIONS:

1. Remove three-inch flange that comes standard with new 3, 5, 7 1/2 and 10 HP InSinkErator disposers, being careful not to damage the bolts or gasket. You'll need these to install the new flange.
2. Insert gasket between two-inch flange and the new disposer as shown in illustration.
3. Install two-inch flange, (Part #13847). Be sure to position with part number facing upward as shown in illustration.
4. Secure flange to disposer using the existing bolts.

Our products appear on **The KCL CADalog** CD-ROM based CAD Foodservice Symbol Library. More information is available from **Kochman Consultants, Ltd.** at [www.kclcad.com](http://www.kclcad.com).



4700 21st STREET  
RACINE, WI 53406  
TEL: 800-845-8345  
FAX: 262 554-3620

[www.insinkerator.com](http://www.insinkerator.com)



The Emerson logo is a trademark and a service mark of Emerson Electric Co.

