



SYMMONS® Lucetta®

Widespread Lavatory Faucet SLW-4612

Installation and Service Instructions



Model Numbers

SLW-4612 Lavatory faucet with pop-up drain

Alternate Finish Code

append to part numbers when applicable

- STN Satin Nickel
- Chrome (standard)

Tools & Materials

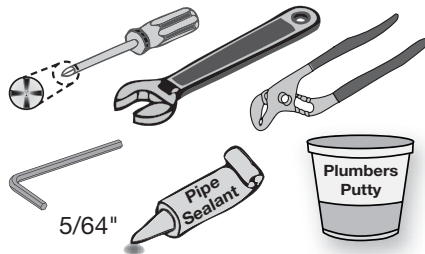

Need Help?

Contact Symmons customer service at (800) 796-6667, (781) 848-2250
 Email: customerservice@symmons.com
 Monday - Friday 8:00 am - 7:30 pm EST

Please check Symmons website for technical help, the latest product information and warranty policy.
www.symmons.com/service

Quick Install Guide *Lucetta Widespread Lavatory Faucet, SLW-4612*

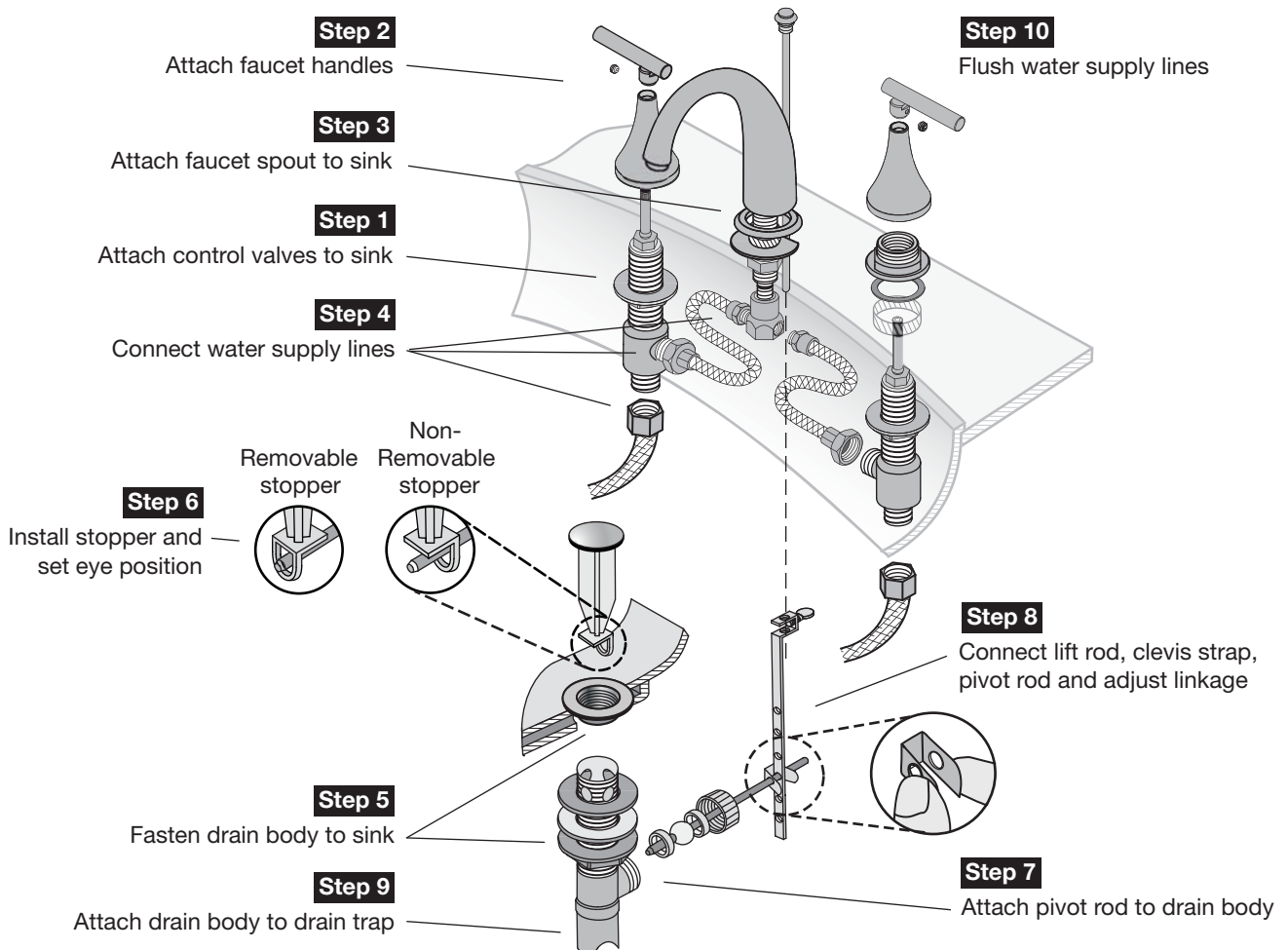

Installation Instructions

Caution: If replacing an older faucet ensure water supply is turned OFF before removing. Then turn faucet control valves ON to relieve water pressure.

Step 1 Attach control valves to sink

- Thread *flange nut* about 2 inches down from threaded end of *valve body*. Ensure larger diameter end is facing up.
- Insert *valve body* from underneath sink up through mounting hole. Ensure valve with red label (hot) is on the left and blue (cold) is on the right.
- Place *gasket* over *valve body* and thread *fastener* onto *valve body* until stop is reached.
- Tighten *flange nut* under sink to secure *valve body*.
- Thread *collar* onto outer threads of *fastener* until against surface of sink.

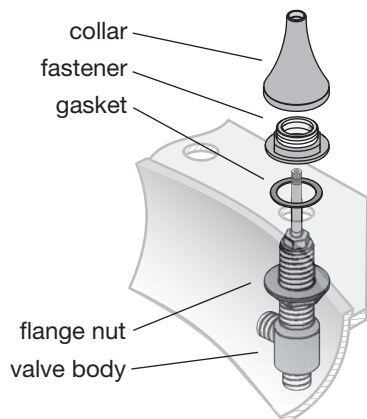

Step 2 Attach faucet handles

- Turn *valve spindles* to the OFF position.
HOT - left valve, clockwise
COLD - right valve, counter clockwise
- Attach handle to valve spindle in OFF location and tighten screw in handle using a 5/64 inch Allen wrench.

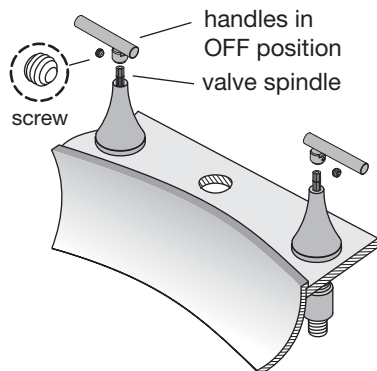

Step 3 Attach faucet spout to sink

- Unscrew *tee* and remove *washer* and *nut* from threaded end of *spout* as shipped.
- Insert end of *spout* through *base* and mounting hole. Fasten from under sink with *washer* and *nut*.
- Tighten *nut* while ensuring *spout* and *base* are centered over mounting hole and flat edge of *washer* is facing rear of sink.

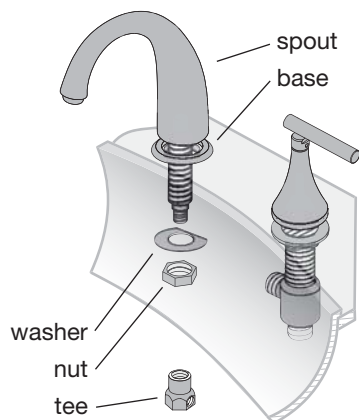

Step 4 Connect water supply lines

- Apply pipe sealant on male end of both *flex hoses* and thread into sides of *tee*.
- Thread center of *tee* with *flex hoses* attached onto end of *spout*.
Note: This may require about 4 inches of clearance to rotate.
- Attach loose end of *flex hoses* to *valve outlets*.
- Plumb hot water supply to left *valve inlet*, cold water to right inlet and fasten with *coupling nuts*.
- Check for leaks if only replacing faucet and drain is already installed by first turning faucet handles to the OFF position and then turn water supply valves ON.

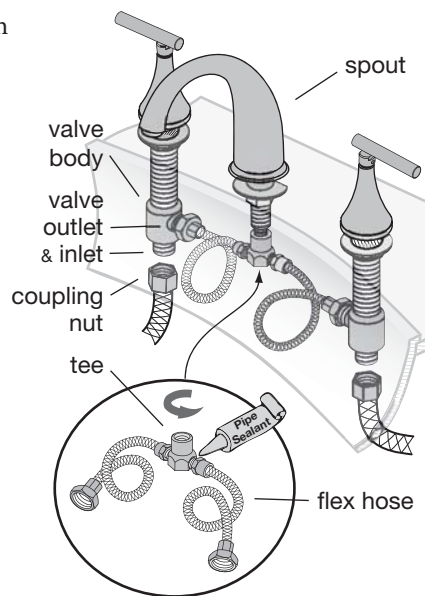

Step 5 Fasten drain body to sink

- Remove *stopper*, unscrew *flange* and remove flat rubber *washer* from end of *drain body* as shipped.
- Apply plumber's putty around bottom of *flange*.
Note: Washer included should only be used when plumber's putty is not available.
- Move *friction washer*, *beveled washer* and *flange nut* down away from end of *drain body*.
- Place *flange* into drain opening and screw *drain body* at least 2-3 turns until hand tight against *flange*.
- Position *drain body* so *pivot cavity* is facing rear of sink and then slide *beveled washer* and *friction washer* up against sink.
- Tighten *flange nut* up against *friction washer* to evenly compress *beveled washer* while also ensuring *flange* is centered in drain opening.
Take care not to over tighten *flange nut*.

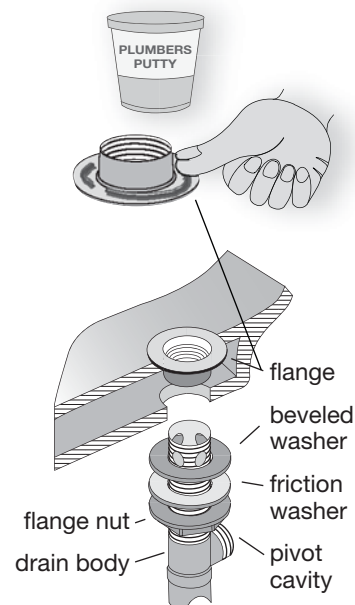

Step 6 Install stopper and set eye position

Stopper can be removable or non-removable determined by position of eye hole when later inserting pivot rod.

- Insert *stopper* through *flange* opening and position eye hole.

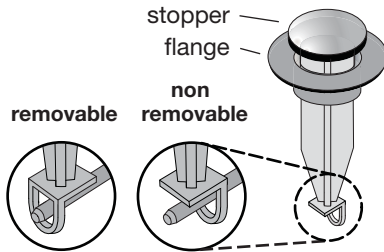

Removing stopper

When installed in removable position, move pivot rod to the up position (lift rod is in the down position when later installed). Eye hole will slide over end of pivot rod.

Step 7 Attach pivot rod to drain body

- Remove *retaining nut* and *outer seat* from *pivot cavity*.
- Insert *pivot rod* into *pivot cavity* so *pivot ball* is against *inner seat* and rod passes under end of *stopper* according to selected eye hole position.
- Slide *outer seat* over *pivot rod* with curved end against *pivot ball*.
- Fasten *pivot rod* to *drain body* with *retaining nut*. Tighten using your fingers until ball is seated snug and *pivot rod* can move around freely.

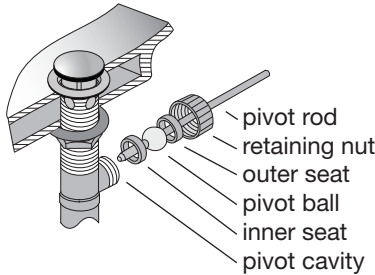

Step 8 Connect lift rod and adjust linkage

- Insert *lift rod* through hole on rear of water spout.
- Fasten end of *pivot rod* with *spring clip* through *location hole* in *clevis strap* that is best aligned to enable *lift rod* also fasten to end of *clevis strap* when in the up position and *stopper* is in the closed position.
- Insert *lift rod* into end of *clevis strap* and fasten with *thumb screw* at location where *stopper* can be easily opened and closed.

If necessary, select another *location hole* in *clevis strap* and re-adjust *lift rod* where fastened to *clevis strap*.

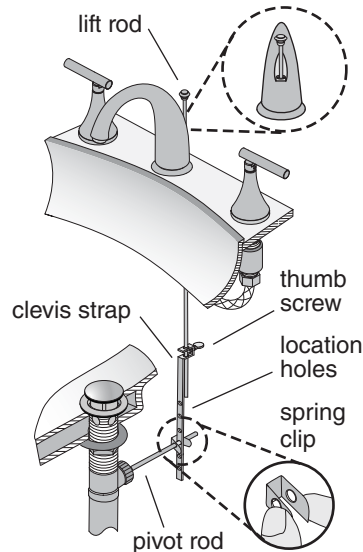

Step 9 Attach drain body to drain trap

Step 10 Flush water supply lines

- Thoroughly flush supply lines to prevent foreign matter, i.e. copper chips, sand, etc. from damaging the sealing surface inside control valves.
- Remove *aerator* from end of faucet water spout.
- Turn hot and cold faucet handles to full ON position and then open water supply valves and run long enough to flush supply lines thoroughly.
- Turn faucet OFF, replace aerator and check for any leaks.

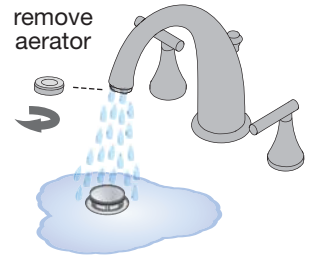

Care of faucet finish

Clean finish area by using mild soap and water or non-abrasive cleaner and then rinse immediately. A non-abrasive wax may be used to preserve finish area.

Valve cartridge replacement

Step 1 Remove faucet handle

Loosen *screw* using a 5/64 inch Allen wrench.

Step 2 Remove collar

Remove collar by turning counter clockwise.

Note: Ensure not to use any tool that could scratch finish without taking protective measures.

Step 3 Remove cartridge

Using a wrench, turn hex nut on *cartridge* counter clockwise.

Note: Ensure valve assembly under sink doesn't rotate while turning nut.

Step 4 Insert new cartridge

Insert replacement *cartridge* and then tighten hex nut.

Step 5 Attach collar

Screw *collar* onto *fastener* and tighten using your hand.

Step 6 Attach faucet handle

- Ensure cartridge spindle is rotated to the OFF position.
- Attach handle in OFF location as shown in illustration and then tighten *screw* using a 5/64 inch Allen wrench.

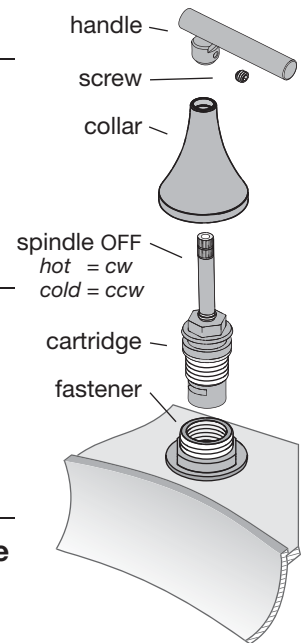

Dimensions *Lucetta Widespread Lavatory Faucet, SLW-4612*

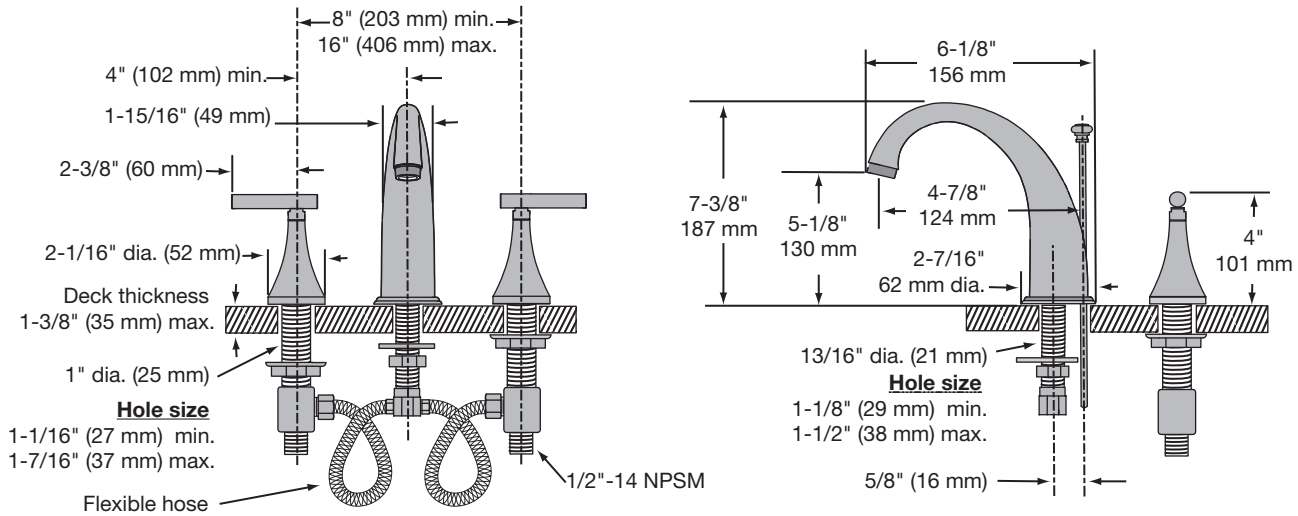

Parts Assembly *Lucetta Widespread Lavatory Faucet, SLW-4612*

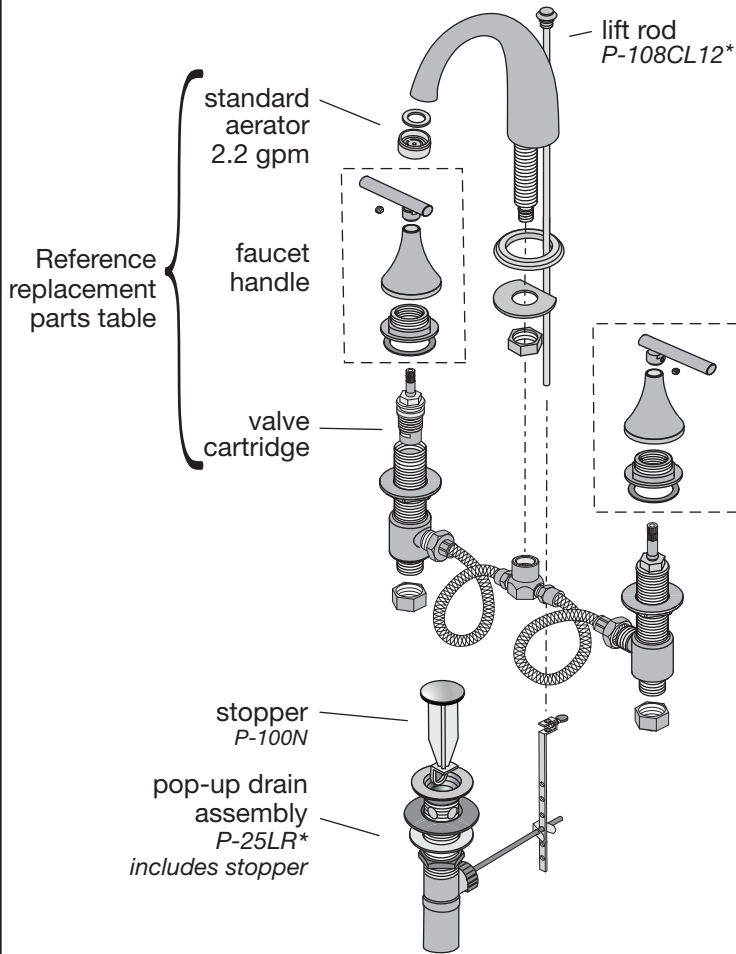

Replacement Parts	
Part Number	Item
WSF-CYL-TP-KIT*	handle set screw collar / escutcheon fastener gasket Set screw requires 5/64" Allen wrench
KN-114E (hot) OFF = CW KN-113E (cold) OFF = CCW	KN-113E identified by groove valve cartridge
LN-15* FLR-110-1.5* FLR-110-1.0*	aerator flow rates 2.2 gpm (8.3L/min) 1.5 gpm (5.7L/min) 1.0 gpm (3.8L/min)

* Note: For faucets with an optional decorative finish, append appropriate three letter suffix code to part numbers marked with an asterisk (*).

Ordering replacement parts:

Call Symmons customer service at (800) 796-6667, (781) 848-2250 M-F 8:00 am - 7:30 pm EST or check our website at www.symmons.com for a list of Symmons distributors.