

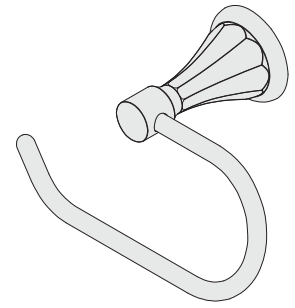

SYMMONS® Canterbury™

Toilet Paper Holder 453TP

Specification Submittal



Model Numbers

- 453TP Toilet Paper Holder

Feature Highlights

- Metal construction,
- Standard finish is polished chrome

Finish Options

Append appropriate -suffix to model number.

- STN Satin nickel finish
- Polished chrome (standard finish)

Warranty

- Limited Lifetime - to the original end purchaser in residential/consumer installations.
- 5 years - for commercial installations

Dimensions *Canterbury Toilet Paper Holder, 453TP*

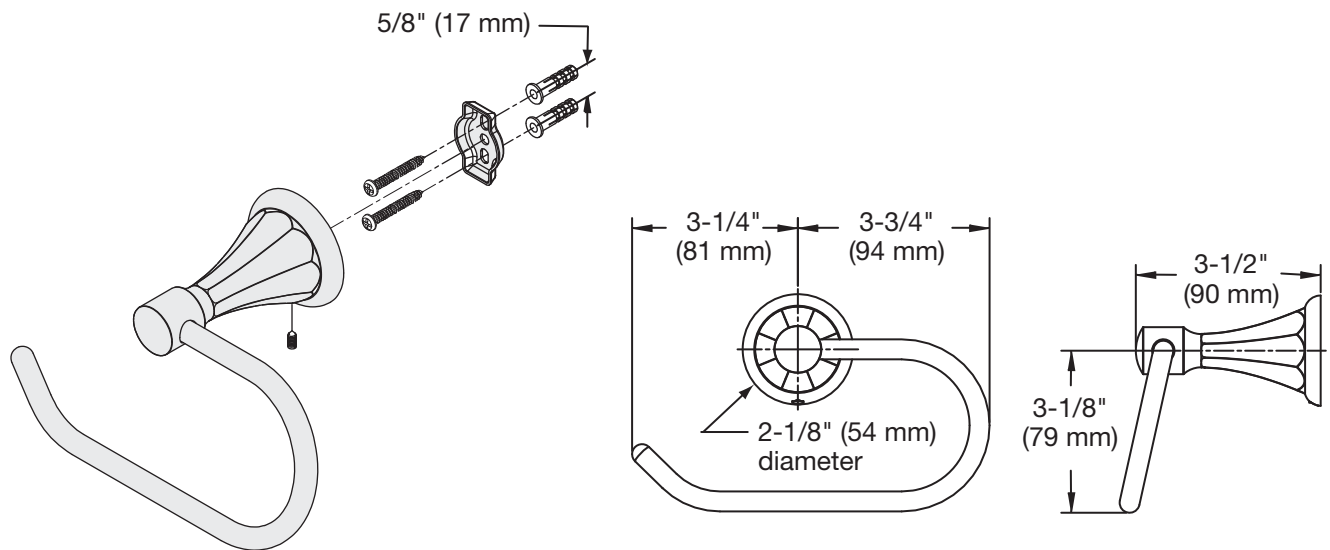

Note: *Dimensions subject to change without notice.*

Symmons Industries, Inc. ■ 31 Brooks Drive ■ Braintree, MA 02184
(800) 796-6667, (781) 848-2250 ■ Fax (800) 961-9621, (781) 843-3849
Website: www.symmons.com ■ Email: customerservice@symmons.com

©2008 Symmons Industries, Inc. Printed in U.S.A. ■ 102808



SYMMONS®
the smart choice™