

SPEAKMAN®

SE-400

EYESAVER® EYE/FACE WASH

DESCRIPTION

The SE-400 Eyesaver® wall mounted eye/face wash provides six aerated sprays for gentle yet thorough rinsing of the eyes and face and features a large rectangular stainless steel bowl, stay open ball valve and an in-line strainer.

SPECIFICATIONS

- Bowl:** 300 series stainless steel or yellow plastic (SE-401)
- Spray Heads:** (6) brass, chrome-plated aerators, plastic covered brass bodies
- Valve:** ½" NPT female brass, chrome-plated
- Activator:** Stainless steel push handle
- Shrouds:** Yellow Polypropylene
- Inlet:** ½" NPT female
- Strainer:** Brass, chrome-plated, in-line
- Performance:** 9.3 gpm @ 30 psi
- Compliance:** ANSI Z358.1
- Universal Emergency Sign Included**

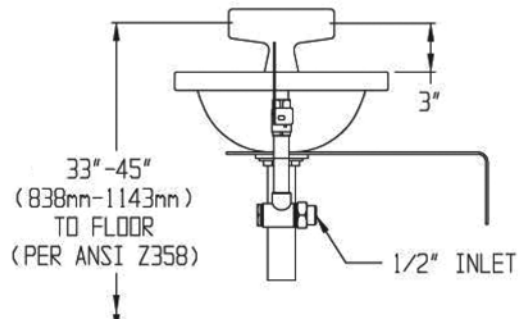

OPTIONS

- FLW Flow switch
- FPV Freeze protection valve
- HFO Hand/Foot operation
- HS Hand-held spray
- PT P-trap
- SPV Scald protection valve
- SSBV2 Stainless steel ball valve

Job Name _____	
Location _____	
Architect/Engineer _____	
Sales Representative _____	
Wholesaler _____	
Date _____	Model # _____

36060