

# Wastewater

## Oil Sensing Sump System™



### Applications

- Little Giant Oil Sensing Sump Systems are ideal for elevator sump pits, transformer vaults and water-and-oil prone confined spaces in accordance with ASME - A17.1

### Features

- Multiple Indicator Lights; Power, Pump Run, High-Water; High Oil, Pump Overload
- Single-piece sensor for easy installation
- ASME - A17.1 compliant
- Includes Remote Alarm
- Alarm panel can be connected to Oil Sensing Sump System's remote panel which contains audio/visual alarming
- Both the main panel and remote alarm panel have auxiliary contacts for connection to a buildings automation system or SCADA system

## Engineering Data

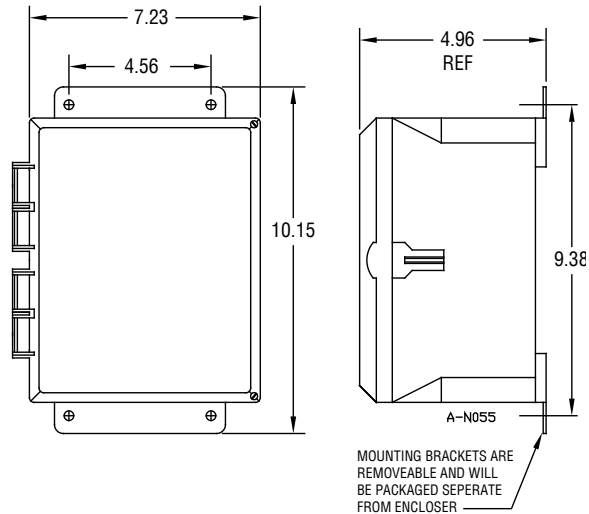
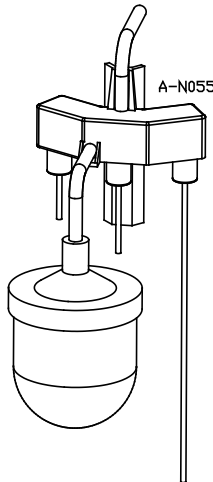

## Specifications

Model No.	Item No.	List/Cert	Volts	Hertz	HP	Overload Range
6E-CIM*	506713	UL/CSA	115V	60 Hz	1/3	N/A
10E-CIM*	511226	UL/CSA	115V	60 Hz	1/2	N/A
10E-CIM*	511277	UL/CSA	208-240V	50/60 Hz	1/2	N/A
OS3-1	513390	UL/cUL	115V	60 Hz	1 Max.	N/A
OS3-1L-5-8	513391	UL/cUL	115V	60 Hz	1 Max.	5-8 Amps
OS3-1L-7-10	513392	UL/cUL	115V	60 Hz	1 Max.	7-10 Amps
OS3-1L-9-13	513393	UL/cUL	115V	60 Hz	1 Max.	9-13 Amps
OS3-2	513395	UL/cUL	230V	60 Hz	2 Max.	N/A
OS3-2L-5-8	513396	UL/cUL	230V	60 Hz	2 Max.	5-8 Amps
OS3-2L-7-10	513397	UL/cUL	230V	60 Hz	2 Max.	7-10 Amps
OS3-2L-9-13	513398	UL/cUL	230V	60 Hz	2 Max.	9-13 Amps
OS3-6E-1**	513380	UL/CSA Pump, UL/cUL Control	115V	60 Hz	1/3	N/A
OS3-10E-1**	513381	UL/CSA Pump, UL/cUL Control	115V	60 Hz	1/2	N/A
OS3-10E-2**	513382	UL/CSA Pump, UL/cUL Control	230V	60 Hz	1/2	N/A

## Construction

### Sensor

Housing: ABS  
 Probe: Stainless steel  
 Float: PVC

### Control Panel

Enclosure: Type 1  
 Power Cord: 6' SJT, 120VAC  
 Receptacle: SJT, 120VAC, 15 amp

### Alarm Panel

Enclosure: Type 1  
 Power Cord: Plug in transformer, 120VAC  
 Backup Power: 9 VDC battery back-up  
 LED Indicators: Trouble, high level, high oil  
 Audible Alarm: 103 db buzzer, auto test/reset

## Typical Installation

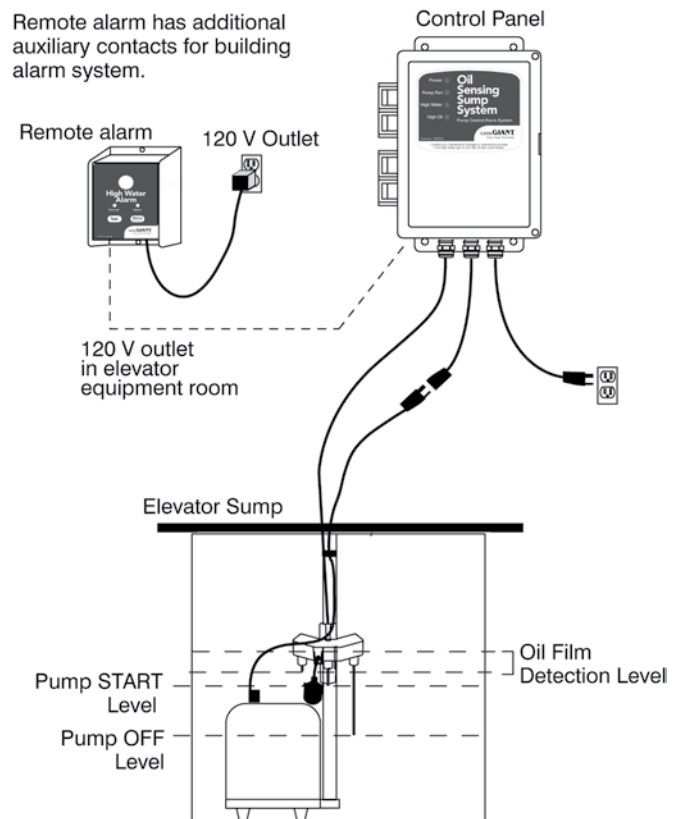

P.O. Box 12010  
 Oklahoma City, OK 73157-2010  
 Phone: 1.800.701.7894  
 Fax: 1.800.678.7867  
 www.LittleGiantPump.com