

# Little GIANT®

## PE-1 H-PW SERIES



### Features

- Environmentally safe, oil-less
- Energy efficient
- 6' cord
- 7' maximum lift
- 36 watts
- 1/4" MNPT discharge
- Flow control accepts 3/8" or 1/2" ID Tubing
- Hooded intake for lower-level water pick-up
- For submersible use only

### Construction

- Motor — 1/125 HP epoxy encapsulated
- Intermittent Liquid Temp. up to — 120°F
- Intake — Screened
- Discharge — 1/4" MNPT
- Housing — Polyester
- Cover — Polyester
- Volute — Polypropylene
- Impeller — Polypropylene
- Shaft Seal — Nitrile®
- Screen — Polypropylene

This pump features an epoxy-encapsulated motor, plastic housing and radial lip seal on the motor shaft. It provides enough power to effectively operate a water garden, statuary, or tabletop fountain. Algae build-up does not effect this small, powerful workhorse. In fact, it may even be used in some harsh, industrial-type applications. This “potted” pump is usually more compact in size than an oil-filled pump of equal flow capacity.

# PE-1 H-PW SERIES

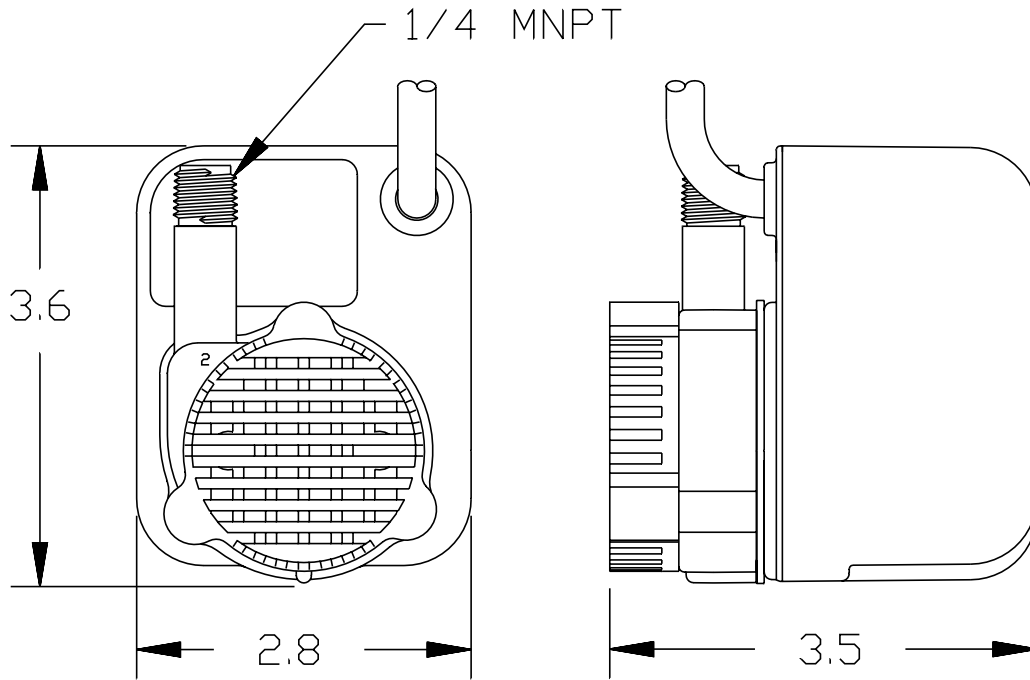

## Specifications

Model No.	Item No.	Discharge Size	Listings	HP	Volts	Hertz	Amps	Watts	Performance (GPH@Head)					Shutoff		Cord Length (ft.)	Weight (lbs.)
									1'	2'	3'	4'	5'	Ft.	P.S.I.		
PE-1H-PW	566621	1/4" MNPT	UL/CSA	1/125	115	60	0.6	36	170	160	140	120	100	7	3.0	6	3.00

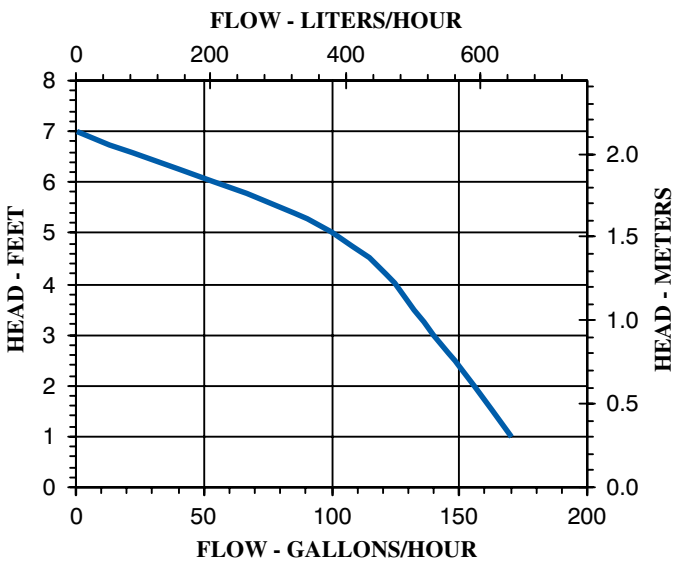

## Replacement Parts

Volute	118340
Impeller	118441
Screen	118901
Gasket	101604
Flow Control	599045