

Seat shall be Comfort™ Seats

Model Number C106CHPM

Commercial Deluxe Plastic Toilet Seat

Elongated Open Front Less Cover

Category

COMMERCIAL

Features

- Injection molded durable polypropylene plastic with UV protection
- External check hinge stops at 11 degrees beyond vertical
- Ergonomical comfort curve seat design
- Corrosion resistant Dacromet™ polymer coated metal hinge
- Built in bumpers
- Non-skid rubberized bushing
- Anti-skid washers
- Hinges are hidden by seat - no pinching

Seat Color/Finish

Specify white

Hinge Color/Finish

Specify white

Product Specifications

Hinge Design: External check hinge with polymer coated metal hinge posts

Ring Thickness: 7/8"

Ring Thickness with Bumper: 1"

Height of Seat with Cover: N/A

Size: ANSI Standard Toilet - Meets Z124.5 Section 5.1.2

Additional Information

All seats feature UV protection.

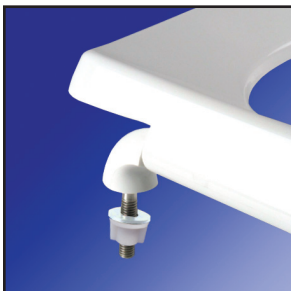
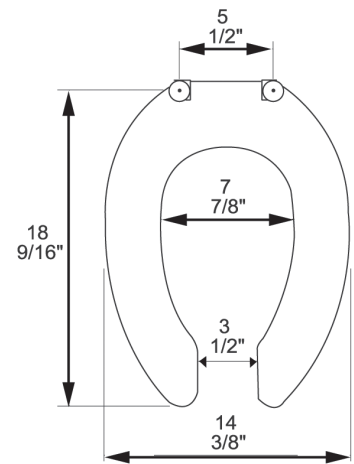

External check hinge with zinc plated metal hinge posts



External check hinge stops seat 11 degrees beyond vertical