

Seat shall be Comfort™ Seats

Model Number C100BBSSCAM

Commercial Juvenile Toilet Bowl

Round Open Front Less Cover

Category

COMMERCIAL

Features

- Injected molded durable polypropylene plastic with UV protection
- Contains Anti-microbial ingredient
- External self-sustaining check hinge stops at 11 degrees beyond vertical
- Built in bumpers
- 304 stainless steel hinge post and hardware
- Built in bumpers
- Hinges are hidden by seat - no pinching

Seat Color/Finish

Specify white

Hinge Color/Finish

Specify white

Product Specifications

Hinge Design: C100BBCAM External check hinge with 304 series stainless steel hardware

Ring Thickness: 1 1/16"

Ring Thickness with Bumper: 1"

Height of Seat with Cover: N/A

Size: Specialty Juvenile Bowl

Additional Information

All seats feature Anti-microbial and UV protection

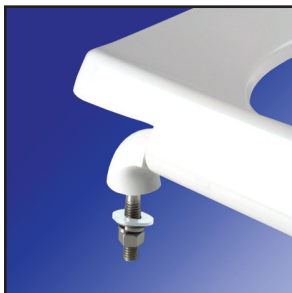
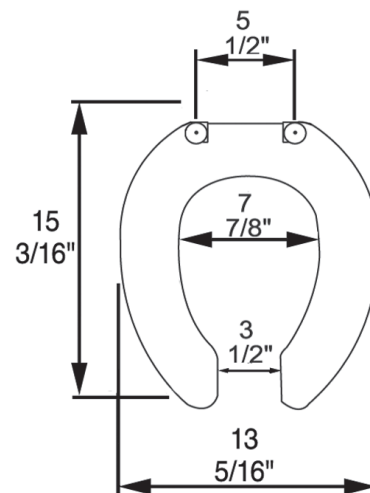

Check Hinge - External check hinge with 304 series stainless steel hinge posts stops seat 11 degrees beyond vertical



Self-Sustaining Check Hinge - External self-sustaining check hinge seat in any raised position up to 11 degrees beyond vertical

