

Electronic Exposed TECK® Flush Valves

**TECK®
COMMERCIAL**



81T201BTA

Exposed Battery Operated 1-1/2" Top Inlet Closet Fixture

- Polished chrome plated vandal resistant metal cover with top mounted sensor operated **H2Optics®** electronics
- Right or left-hand supply installation
- ADA compliant, automatic operation battery powered infrared sensor
- Scratch resistant replaceable lens window
- Four (4) size AA alkaline batteries factory installed with valve in sleep mode for easy installation
- Hinged battery housing for easy maintenance
- Low battery flashing light (5000 flushes remaining) with battery strength indicator
- Infrared sensor range adjustment of 610mm-1067mm (24" - 42"), factory set at 34" (±2")
- Optional 24 hour automatic flush factory set to OFF, 3 second flush delay
- Set-up sensor range adjustment indicator lights
- 6 VDC input, 8 second arming delay
- Electronic operated non-hold-open **metal** manual override button with 5 second lockout
- Quiet action, TECK® exposed diaphragm flush valve
- Chloramine resistant diaphragm
- Forged brass diaphragm retainer
- Renewable seat
- Polished chrome plated finish
- **External water conserving flush adjustment**, factory set at 60 PSI to 6 litre (1.6 US gal.) (except -48 and -6 models)
- **1" FIP/Copper sweat inlet adaptor**, angle check stop with protecting cap
- Adjustable 121mm (4-3/4") plus or minus 11mm (7/16") inlet/valve outlet centers
- Vacuum breaker
- Cover tube, stainless steel wall flange, spud flange, concealed spud nut, and 292mm (11-1/2") outlet tube.

81T201BTA-6

Same as 81T201BTA,
but **Not Field Adjustable**

81T201BTA-48

Same as 81T201BTA, but factory set at 60 PSI to 4.8 litre (1.27 US gal.), **Not Field Adjustable**

81T221BTA

Same as 81T201BTA,
but with 610 mm (24") outlet tube

81T221BTA-6

Same as 81T221BTA, but **Not Field Adjustable**

81T221BTA-48

Same as 81T221BTA, but factory set at 60 PSI to 4.8 litre (1.27 US gal.), **Not Field Adjustable**

Approvals:

- CSA certified
- Complies to ASSE 1037
- ADA Compliant and meets Handicapped Accessibility Standard ASME A117.1 of less than 5 lbs. operating force.

(Contact Delta Representative for State and/or Local Approvals.)
U.S. Patent # 6, 826, 455
Other Patents Pending



Engineer/Architect Approval

Model Specified:

Approval:

Date:



81T201BTA

Electronic Exposed TECK® II Flush Valve Retrofit Kits

81T201BTA-20

Same as 81T201BTA, but LESS stop, cover tube and wall flange

81T201BTA-20-6

Same as 81T201BTA-20, but **Not Field Adjustable**

81T201BTA-20-13

Same as 81T201BTA-20, but factory set at 60 PSI to 13 litre (3.4 US gal.)

81T201BTA-20-48

Same as 81T201BTA-20, but factory set at 60 PSI to 4.8 litre (1.27 US gal.), **Not Field Adjustable**

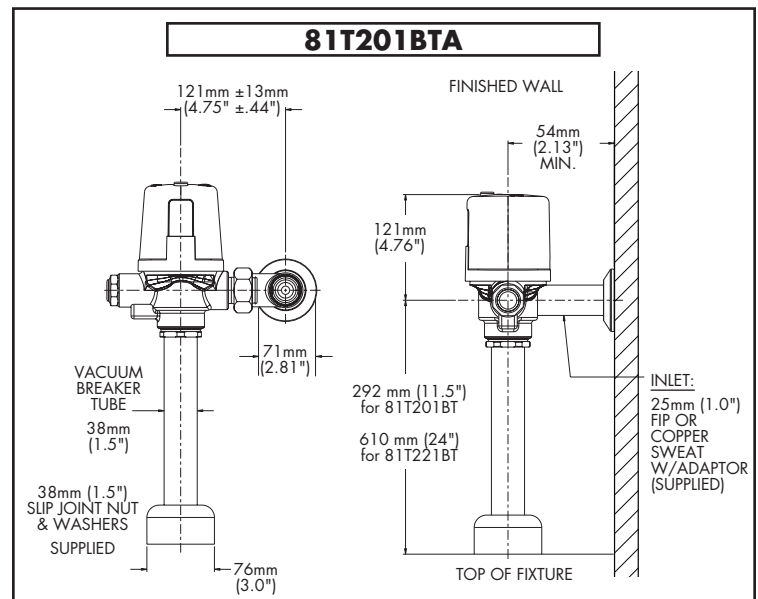

Note: For high and low pressure applications, please see page FEA-81T High Water Pressure note for more details.
Verify flow requirements with bowl manufacturer.

Note: Measurements may vary ± 6mm (0.25")

Refer to www.specselect.com for individual models.

Note: Use this page as a product submittal sheet.